

Operating Instructions

EBE 350 VH

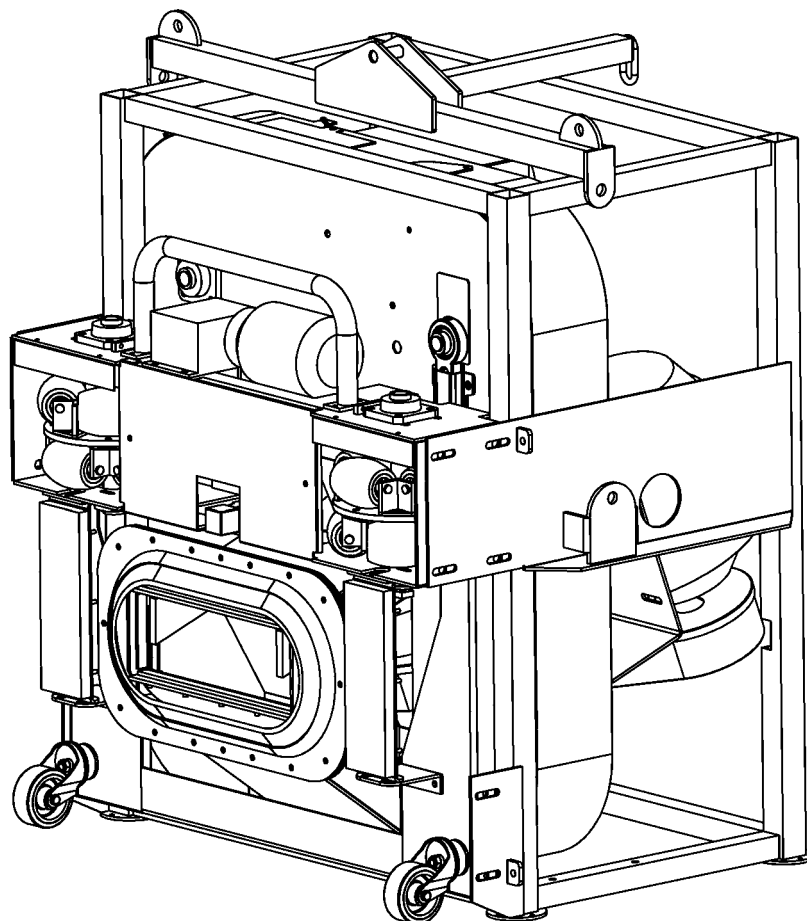

 **BLASTRAC**

MAN-EBE 350VH-EN

ISPC Blastrac/EBE
Utrechthaven 12
3433 PN Nieuwegein
THE NETHERLANDS
T +31(0)30 - 601 88 66
F +31(0)30 - 601 83 33
E info@surfacepreparation.nl
I www.surfacepreparation.com



Technical data	1
Safety instructions	2
General	3
Transport	4
Initial operation	5
Operation	6
Maintenance	7
Electrical systems	8
Fault diagnosis	9
Spare parts	10

Contents Chapter 1

1.1 Rating

1.2 Unit specifications

1.3 Operative range and correct usage

1.4 Stand-by power supply (generator)

1.5 Machine type designation

1.6 Advice for operators of blast cleaning machines

Technical data
1.1 Rating

Unit / designation : **ISPC Blastrac/EBE** blast cleaning machine

Machine type : EBE 350 VH

Manufacturer : **ISPC Blastrac/EBE**
 Utrechthaven 12
 NL-3433PN Nieuwegein
 THE NETHERLANDS

1.2 Unit specifications

Dimensions:

	Machine EBE 350 VH	
Length	900	mm
Width	1050	mm
Height	1250	mm
Weight	525	kg

Connected loads (electrical system):

The indicated input current values correspond to the nominal current values of the motors working under full load. These values are not achieved under normal operating conditions.

	Power consumption	Input current
EBE 350 VH Blast wheel drive	11.0 / 13.0 kW	max. 20 A
Elevator motor	0.75 kW	max. 2.0 A
Drive motor	0.18 kW	max. 1.0 A
Actuator	0.5 kW	max. 1.5 A

Electrical connection required : 400-480 V, 50/60 Hz, 32 A

1

Technical data

	Rated speed	Freq.	Enclosure
Drive of blast wheel	2920 / 3525 min ⁻¹	50/60Hz	IP 55
Elevator motor	125 / 150 min ⁻¹	50/60Hz	IP 55
Drive wheel motor	675 / 810 min ⁻¹	50/60Hz	IP 55



- Blast wheel size : 225 mm Ø
- Working width : 300 mm
- Drive speed : 0 - 15 m/min
- Blast cleaning output on steel : up to 35 m²/h
- Dust hose connection : 130 mm Ø
- Recommended abrasive : Shot 330-390-460
SG25-18-16
- Abrasive consumption : 0,1 - 0,5 kg/m²
- Recommended filter unit : EBE 350 DAAM UNI

1.3 Operative range and correct usage

The EBE 350 VH is exclusively designed to clean dry, frost-free vertical surfaces. The machine may not be used for other purposes. The manufacturer will not be liable for damage resulting from such incorrect usage. In these cases the user assumes all risks.



Technical data

1.4 Stand-by power supply (generator)



If the EBE 350 VH blast-cleaning machine is operated using a generator, this generator must be operated in accordance with the current VDE directives (this applies to the protective earth conductor in particular) in order to ensure that all safety devices are functioning and to eliminate possible damage to electrical components.

1.5 Machine type designation

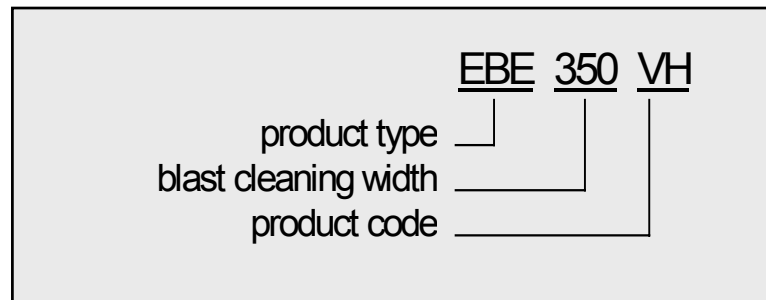

1.6 Advise for operators of blast cleaning machines



In accordance with the accident prevention regulations for blast cleaning work (VBG 48) the operator must provide operating instructions for blast cleaning work in a form and language that is understandable.

The blast-cleaning machine Operating Instructions is only part of these operating instructions. Please consult the current accident prevention regulations for the precise content.

Contents Chapter 2

2.0 Warnings and symbols

2.1 Organisational measures

2.2 Personnel selection and qualification

2.3 Safety precautions applicable to different operating conditions

2.4 Special work within the scope of use of the equipment and maintenance activities as well as repairs during operation

2.5 Definition of the **Safety off position**

2.6 Particular dangerous aspects of the equipment

2.7 Electrical engineering regulations

2.8 Important safety precautions

Safety instructions

2.0 Warnings and symbols

The following denominations and symbols are used in the Operating Instructions to highlight areas of particular importance:

2



Symbol of operational safety.
 In these Operating Instructions this symbol will be shown next to all safety precautions that are to be taken in order to ensure prevention to life and injury. Follow these instructions and take special care in these circumstances. In addition to these instructions, the general safety precautions and accident prevention guidelines are also to be followed.



Particular details regarding the economical use of the equipment.



Information, instructions and restrictions with regard to possible risks to persons or to extensive material damages.

Warning against dangerous voltages.



Indications relating to protective devices in electrical appliances.



2

Indications where consultation with the manufacturer is required.



Instructions relating to periodical checks.



Reference to important instructions contained in the Operating Instructions.



2.1 Organisational measures

The **Operating Instructions** are to be kept **near the location where the machine** is located and must be **within reach at all times!**



In addition to the Operating Instructions general and legal regulations regarding accident prevention and environmental protection must be complied with and indicated!

Such duties may for example relate to the handling of hazardous substances or to the provision and wearing of personal protection equipment as well as compliance with traffic regulations.

Safety instructions

The Operating Instructions must be **supplemented** by **instructions** including the duty to **supervise** and **report** relating to **particular working practices**, for example work organisation, work procedures and personnel allocation.

2 Personnel entrusted with working with the machine must have read the **Operating Instructions** before starting work, in particular the **Safety Instructions** chapter. To read these instructions during work is too late. This particularly applies to incidental activities such as setting up the equipment, carrying out maintenance work or training staff to work with the machine.

From time to time the working practices of the staff are to be checked regarding awareness of **safety and hazards**.

Personnel must tie back long hair and not wear loose clothing or jewellery including rings. There is a risk of injury through getting stuck or being drawn into moving machinery.



Use **personnel protection equipment** if necessary or required by regulations! Take notice of **all** safety and hazard notices on the machine!

All **safety and hazard notices** at or on the machine must be kept complete and **legible**!

If **safety-critical changes** occur to the machine or its working method, the machine must be **shut down immediately**! The cause of the fault must be established immediately!



Changes, add-ons or conversions to the machine, which might impair safety, must not be undertaken **without the manufacturer's permission**!

This applies in particular to the fitting and adjustment of safety devices as well as to welding on load-bearing parts.

Spare parts must comply with the technical requirements specified by the manufacturer. This is always guaranteed if original spare parts are used.

Intervals for recurring **checks and inspections** specified in these Operating Instructions must be complied with!

Safety instructions

To perform maintenance work correctly it is imperative to be equipped with the proper tools for the task in question.

The **location** and the operation of **fire extinguishers** must be made known on each building site!

Take note of the facilities for reporting and fighting fires!

A grey right-angled triangle pointing to the right, containing the number "2" in a white, sans-serif font.

2.2 Personnel selection and qualification

Fundamental duties :

Work on the machine may only be undertaken by **reliable personnel**.

Only trained personnel may be deployed. **Note the statutory minimum age!** Specify clearly the responsibilities of personnel for operation, setting up, servicing and maintenance work!

Make sure that only **authorised** personnel operate or work on the machine!

Define responsibilities of the machine operator also regarding to traffic **safety regulations** and empower him to decline instructions from third parties, which are not complying with the safety requirements!

Personnel being trained or made acquainted with the equipment may only be deployed on the machine **under constant supervision of an experienced person!**

Safety instructions

2.3 Safety precautions applicable to different operating conditions

Ban any method of working that **impairs safety!**

2



Only operate the machine when all **safety devices** and related **safety equipment**, e.g. detachable **safety devices**, emergency stops and suction devices are present and **operational!**

Check the machine visually for any **damage** and **defects** at least once a day!

In the event of **operational malfunctions** the machine must be **shut down immediately** and secured, and the fault must be rectified!



Secure the **work area** around the machine in **public areas** providing a **safety distance** of at least 2 m from the machine.

Before switching on the machine make sure that no one can be endangered when the machine starts up!

Do not switch off or remove the exhaust and ventilation devices when the machine is running!



All persons in the proximity of the machine must wear ear protectors, safety glasses with lateral protection as well as safety shoes. The operator is obliged to wear close-fitting protective clothing.



Use only extension cable for extending the main cable that are sized and marked in accordance with the overall power consumption of the machine and the valid VDE guidelines.

Safety instructions

2.4 Special work within the scope of use of the equipment and maintenance activities as well as repairs during operation

Mechanical servicing work:

Put the machine in the **Safety off position** as described in chapter 2.5 for any servicing work on the machine in order to prevent the machine from being **switched on** accidentally.

Please follow any special **safety instructions** in the various chapters on servicing the machine.

See chapter 7.1 - 7.9.

Adjustment, servicing and inspection work and time limits specified in these Operating Instructions as well as any information on the replacement of parts and equipment must be **undertaken and/or complied with!**

These activities may only be undertaken by **qualified personnel**.

Do not use any **aggressive** cleaning materials!
Use lint-free **cleaning cloths!**

Always tighten any screw connections that are undone during servicing and maintenance work!

If **safety devices** need to be **dismantled** during setting up, servicing and repairs, these **safety devices** must be **reinstalled** and inspected immediately after completion of the servicing and repair work.

Make sure that process materials and replaced parts are disposed of safely and in an environmentally friendly manner!

Electrical servicing work:

Make sure that electrical components used for replacement purposes comply with the original parts and are correctly adjusted if necessary.

For safety notes see 2.7 Electrical engineering regulations.

Safety instructions

2.5 Definition of the Safety off position

Definition:

The machine is in a safe condition when it cannot generate any hazard.

Putting the equipment in the Safety off position means:

- Close the valve.**
- Switch off the blast machine.**
- Switch off the dust collector.**
- Wait for standstill of all drives.**
- Pull out mains plug.**

Safety instructions

2.6 Particular dangerous aspects of the equipment

Any machine, if it is **not used according the regulations**, may be **hazardous** for operating, setting-up and service personnel. The **operating authority** is responsible for **compliance with the safety regulations** during operation and maintenance of safety **devices** supplied with the machine as well as the provision of appropriate additional safety devices!



2

	<p>1. Blast housing outlet</p> <p>Danger of injury!</p> <p>Abrasive leaves housing with high speed! Moving parts!</p> <p>Lift and cant the machine only when it is in Safety off position.</p> <p>It is not allowed to stay within the working radius of the machine!</p>
--	--------------------------------------------------------------------------------------------------------------------------------------------------------------------------------------------------------------------------------------------------------------------------------------

	<p>2. Wheels</p> <p>Danger of injury!</p> <p>Moving parts!</p> <p>It is not allowed to stay within the working radius of the machine!</p>
--	--------------------------------------------------------------------------------------------------------------------------------------------------

Safety instructions

2.7 Electrical engineering regulations

2



Work on **electrical** equipment or operating materials may only be undertaken by a **skilled electrician** or by **trained** persons under the **guidance** and **supervision** of a **skilled electrician** as well as in accordance with the **electrical engineering regulations**.



Use only extension cable for extending the main cable that are sized and marked in accordance with the overall power consumption of the machine and the valid VDE guidelines.



The electrical equipment for the plant must **inspected regularly**. Please note in particular the **specified recurring inspections** according **EN60204-1**. Defects such as **loose** connections or **scorched** cables must be rectified **immediately**. **Call a skilled electrician or our Customer Services**.

A **second** person must be deployed who can pull out the plug in an emergency if work on **live** parts is necessary. The work area must be sealed off using a red and white **safety chain** and a danger sign. Use a tool that is **insulated against voltages**.

Only start work once you are familiar with the **electrical engineering regulations** that apply to your area.

Only use voltage seekers that **comply with the regulations** when troubleshooting. From time to time check voltage seekers to ensure that they are operationally efficient.

2.8 Important safety precautions

Please read these instructions carefully and completely before operating this equipment.

1. Do not operate this equipment wearing loose fitting clothing in the vicinity of any moving parts.
2. Keep your hands away from moving parts.
3. Safety goggles and adequate ear protection devices must be worn by all personnel in the vicinity of the equipment while in operation.
4. Do not operate this equipment on a wet surface or in the vicinity of any flammable liquid or vapors.
5. Prior to starting this equipment make sure all belts are in good condition, are in place and adjusted to the proper tension.
6. Do not maintain, repair or climb on this equipment in a suspended position.
7. Disconnect electrical supply before working on this equipment.
8. Do not stand under suspended machine.
9. No unauthorized person may operate this machine.

Warning

ISPC Blastrac/EBE machines build for the American market are special build to run on 440-480V and 60Hz. If the machines are operating on a Voltage or Hz lower than 440V and 60Hz, it will damage the electric components.

It is not permitted to make any modifications or changes on the ISPC Blastrac/EBE blasting equipment without written permission by ISPC Blastrac/EBE.

Contents Chapter 3

- 3.1 Introduction
- 3.2 Operating instructions
- 3.3 Connections
- 3.4 Care and maintenance
- 3.5 Scope of supply
- 3.6 Description
- 3.7 Control box
- 3.8 Operating elements
- 3.9 Blast wheel
- 3.10 Separator and hopper
- 3.11 Elevator
- 3.12 Drive system
- 3.13 Abrasive sealing
- 3.14 Air suction and filter system
- 3.15 Abrasive media

General

3.1 Introduction

ISPC Blastrac/EBE wants to thank you for your decision to employ the blast cleaning machine EBE 350 VH for the treatment of vertical surfaces.

The machine has a closed abrasive circuit with dust separation. This comprehensively avoids damaging the environment and endangering the operating staff.

The EBE 350 VH is designed to remove (epoxy) coatings on different types of vertical surfaces.

3.2 Operating instructions

This manual has been written to support the operating personnel on learning the functioning of the machine and to guarantee optimum operation and maintenance.



Therefore it is important that all persons operating and maintaining the machine read this manual carefully and understand it fully.

The supplied machine has been manufactured for being employed in the user's country. All descriptions and notes have been formulated in the language of the user's country or in English in accordance with the statutory regulations, or shown as pictograms. If the customer deploys personnel with little knowledge of the language of the user's country, appropriate instruction and training must be provided.



Before using the machine personnel must be familiar with how to operate the machine, with all important components, with the method of working and with its dimensions.



ISPC Blastrac/EBE offers a course on the use of the machine in order to make the operating and maintenance personnel familiar with all elements of the blast-cleaning machine.

3

General

Initial commissioning of the machine must be carried out very carefully. The machine operator must fully understand the sequence of commissioning of the individual parts and their functioning.



All persons in the proximity of the machine in operation must wear ear protectors, safety glasses with lateral protection and safety shoes. The machine operator must wear close-fitting protective clothing.



3.3 Connections

Machine	Voltage	Connection type
EBE 350 VH	400/480V 50/60Hz	32A

3.4 Care and maintenance

Special attendance and regular maintenance of the machine and its parts are imperative for functioning and safety.

In order to prevent unnecessary downtimes it is recommended to keep original spare and wear parts on stock as listed in the maintenance box.

A list of contents of the maintenance box is provided in Chapter 10 to enable the above-mentioned work to be carried out quickly.



WARNING: ISPC Blastrac/EBE machines build for the American market are especially build to run on 440-480V 60Hz. If the machines are operating on a Voltage or Hz lower than 440V and 60Hz, this will damage the electric components.



General**3.5 Scope of supply**

Scope of supply of the machine:

- Blast cleaning machine (EBE 350 VH)
- Dust hose
- Operating instructions (2 x)
- Maintenance box (option)

3.6 Description

Fig. 3.1

- | | | | |
|---|----------------|----|-------------------|
| 1 | Hoist beam | 6 | Abrasive hopper |
| 2 | Bobbin frame | 7 | Blast motor |
| 3 | Blast body | 8 | Shot valve unit |
| 4 | Separator | 9 | Blast wheel group |
| 5 | Elevator frame | 10 | Main box |

General

The **ISPC Blastrac/EBE** blast-cleaning machine EBE 350 VH is a blast machine with a closed abrasive circuit designed for the pre-treatment of vertical surfaces. The bouncing impact of metallic abrasive onto the surface to be treated thoroughly removes surface contaminants, coats of paint, sealants and thin coatings.

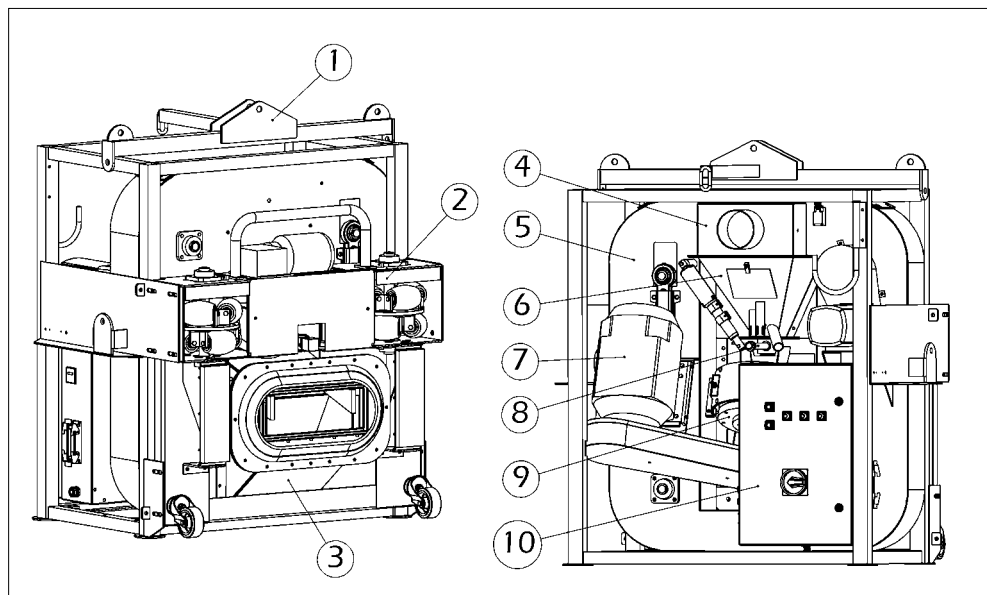
Like many revolutionary inventions the blast wheel method is based on a simple principle: after mechanical pre-acceleration the abrasive is thrown onto the surface at high speed by the blast wheel. Once the abrasive has impacted on the surface it rebounds into a recovery duct. The recovery duct deflects the abrasive into an air current separator. Here dust and other contaminants are removed from the abrasive so that only abrasive containing a very small amount of dust is fed into the abrasive storage hopper for re-use by the blast wheel.

A suitable filter unit must be connected to the machine in order to separate the dust from the abrasive.

A specially designed dust collection system ensures dust-free operation of the machine and clean air at the workspace.

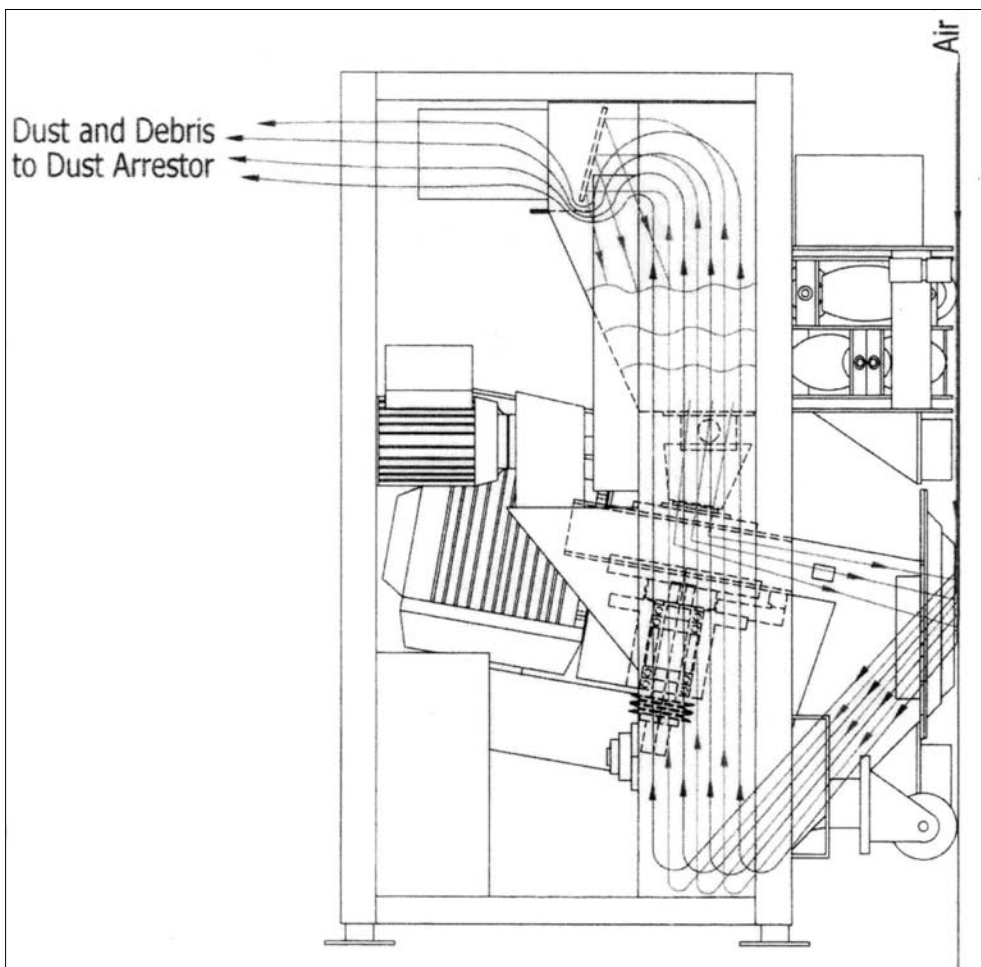
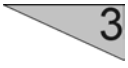

Fig. 3.2

General

3.7 Control box

The control box is equipped with all control elements and instruments for monitoring and controlling the blast-cleaning machine.

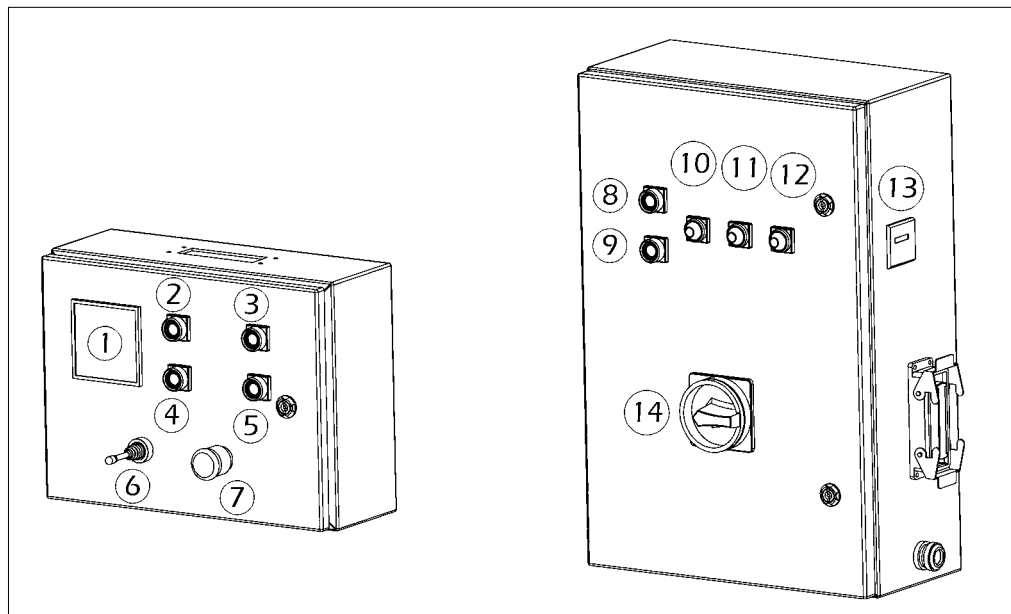

Fig. 3.3

- | | | | |
|---|-----------------------------------|----|-----------------------------|
| 1 | Ammeter | 8 | Push button "Elevator ON" |
| 2 | Push button "Main blast ON" | 9 | Push button "Elevator OFF" |
| 3 | Push button "Shot control +" | 10 | Control lamp "Power" |
| 4 | Push button "Main blast OFF" | 11 | Control lamp "Main blast" |
| 5 | Push button "Shot control -" | 12 | Control lamp "Shot control" |
| 6 | Drive wheel joystick left / right | 13 | Hour counter |
| 7 | Emergency shutdown switch | 14 | Main switch |

Main switch

The main switch is located on the main box at the rear of the machine. It has to be switched on before operation.

Emergency shutdown switch

The emergency shutdown is a red mushroom-shaped press switch. Pressing this switch immediately interrupts power supply to all machine components. Releasing this switch makes the control lamp "Power" light up.

3

General

Push buttons "Elevator ON/OFF"

Pressing the push button "Elevator ON" starts the elevator motor to drive the bucket elevator.

Pressing the push button "Elevator OFF" stops the elevator motor, and thus the bucket elevator.

Push buttons "Main blast ON/OFF"

Before pressing this button make sure that the shot valve is closed. Pressing the push button "Main blast ON" switches the blast wheel motor on. Pressing the push button "Main blast OFF" cuts off the motor power supply immediately. Pay attention that the blast wheel will continue rotating for some time after pressing the OFF button!

Push button "Shot control + / -"

Pressing the push button "+": the abrasive control valve will open as long as this button is activated (max. 20 A).

Pressing the push button "-": the abrasive control valve will close as long as this button is activated.

Drive wheel joystick left/right

Operating this joystick makes the machine move to the left or the right.

Ammeter

The ammeter shows the load consumption of the blast wheel motor. When switching on the motor the current value is high (starting current peak) and falls, after having reached the idle speed, to approximately 8 A. With full load it may rise to a maximum of 20 A.

Hour counter

The hour counter on the main box shows the sum of the actual working hours performed by the blast wheel.

General

3.8 Operating elements

The shot valve

Between the abrasive storage hopper and the blast housing there is a valve in order to control the abrasive flow towards the blast wheel. Any change in the opening of the valve causes the amount of abrasive fed to the blast wheel to change. The change in the abrasive fed can be read from the ammeter. The valve is operated by the shot valve actuator and can be adjusted so that any quantity of abrasive can be fed to the blast wheel. Optimum blast cleaning power is reached when the ammeter indicates 15 - 20A. It is not permitted to blast with a higher current value.

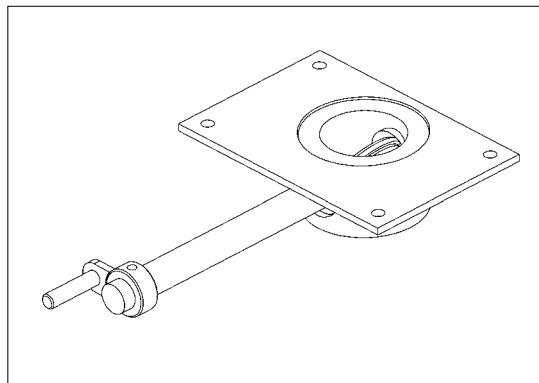

Fig. 3.4

The shot valve actuator

This component is located at the front side of the hopper and regulates the shot valve to control the flow of abrasive towards the blast wheel. While pushing the “+” button, the shot valve will open and abrasive is allowed to travel towards the blast wheel in a progressive, controlled manner (max. 20 A). While pushing the “-” button, the shot valve will close.

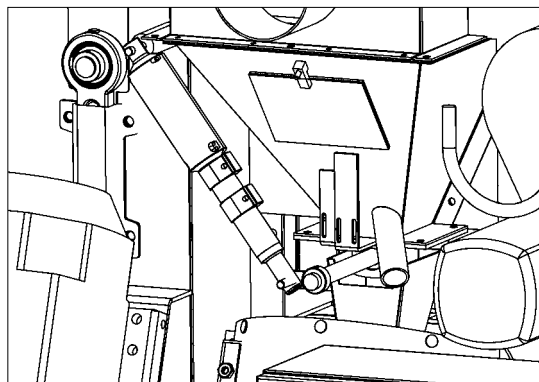

Fig. 3.5

3

3.9 Blast wheel

The heart of the blast cleaning machine is a blast wheel that throws the abrasive onto the surface to be cleaned by using centrifugal force. The blast wheel is placed in a protective housing lined with replaceable wear parts. The blast wheel is driven by an electric motor.

Around the centre of the blast wheel there is the impeller feeding dosed quantities of abrasive onto the blades of the turning blast wheel. On top of this is the control cage (with 1 notch) which, once it is carefully set, regulates the flow of abrasive.

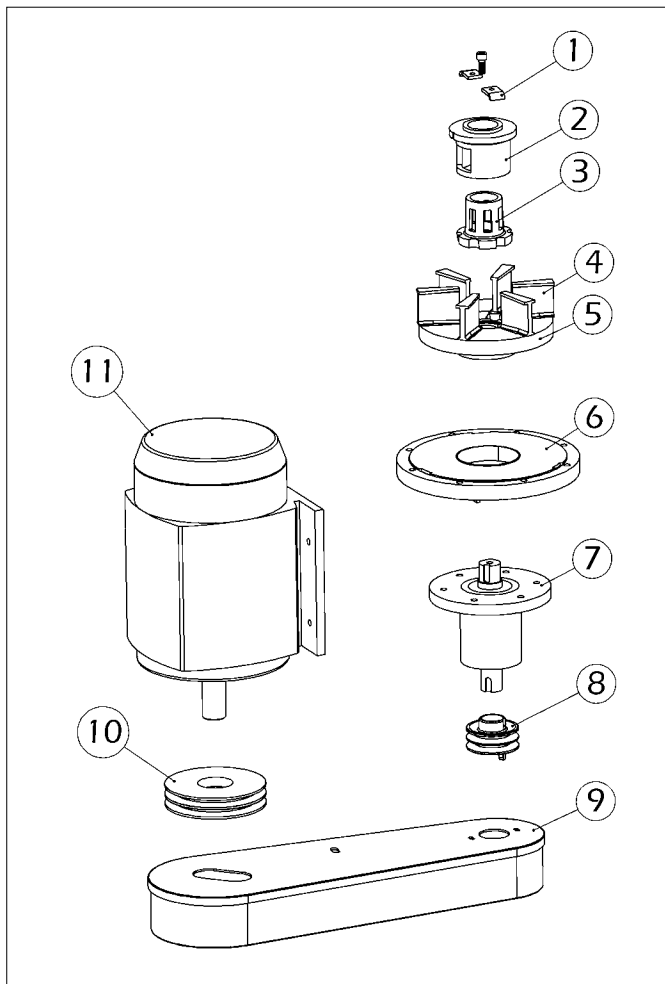

Fig. 3.6

- | | | | |
|---|----------------------|----|-------------------|
| 1 | Control cage clamp | 7 | Bearing unit |
| 2 | Control cage | 8 | Pulley |
| 3 | Impeller | 9 | Belt guard |
| 4 | Blades (set of 6) | 10 | Pulley |
| 5 | Blast wheel | 11 | Blast wheel motor |
| 6 | Motor adaption plate | | |

General**3.10 Separator and hopper**

The abrasive separator is part of the top of the elevator housing. It separates the abrasive from contaminants and feeds the cleaned abrasive back to the abrasive storage hopper.

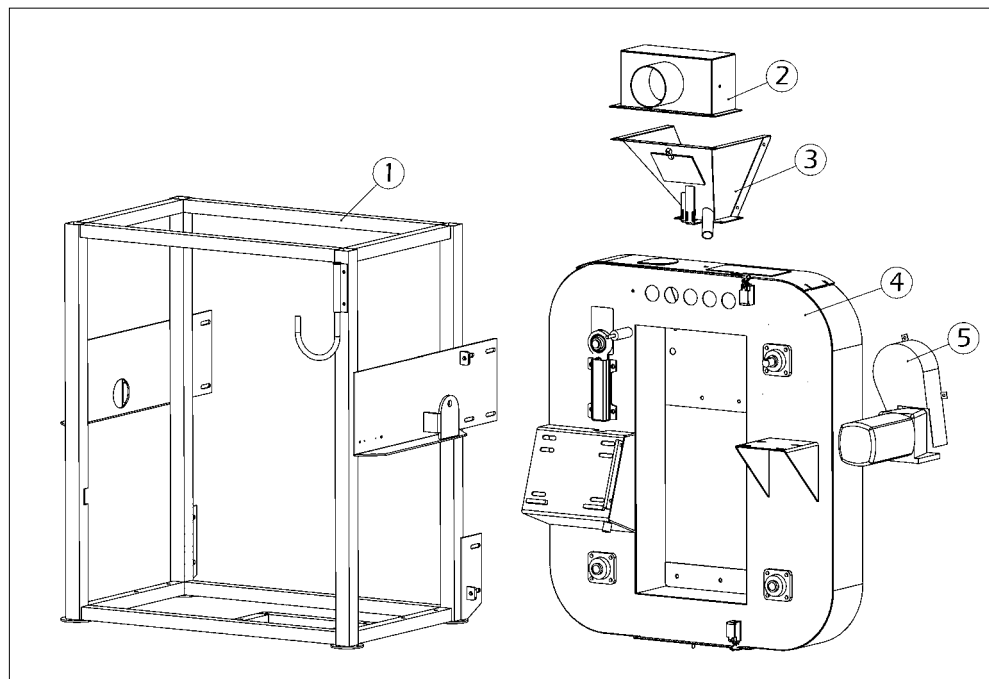

Fig. 3.7

- 1 Protection frame
- 2 Separator (part of elevator housing)
- 3 Abrasive storage hopper
- 4 Elevator housing
- 5 Elevator drive & chain guard

3.11 Elevator

The function of the elevator is to convey abrasive and debris to the top of the machine. In addition the elevator housing provides airflow through the machine.

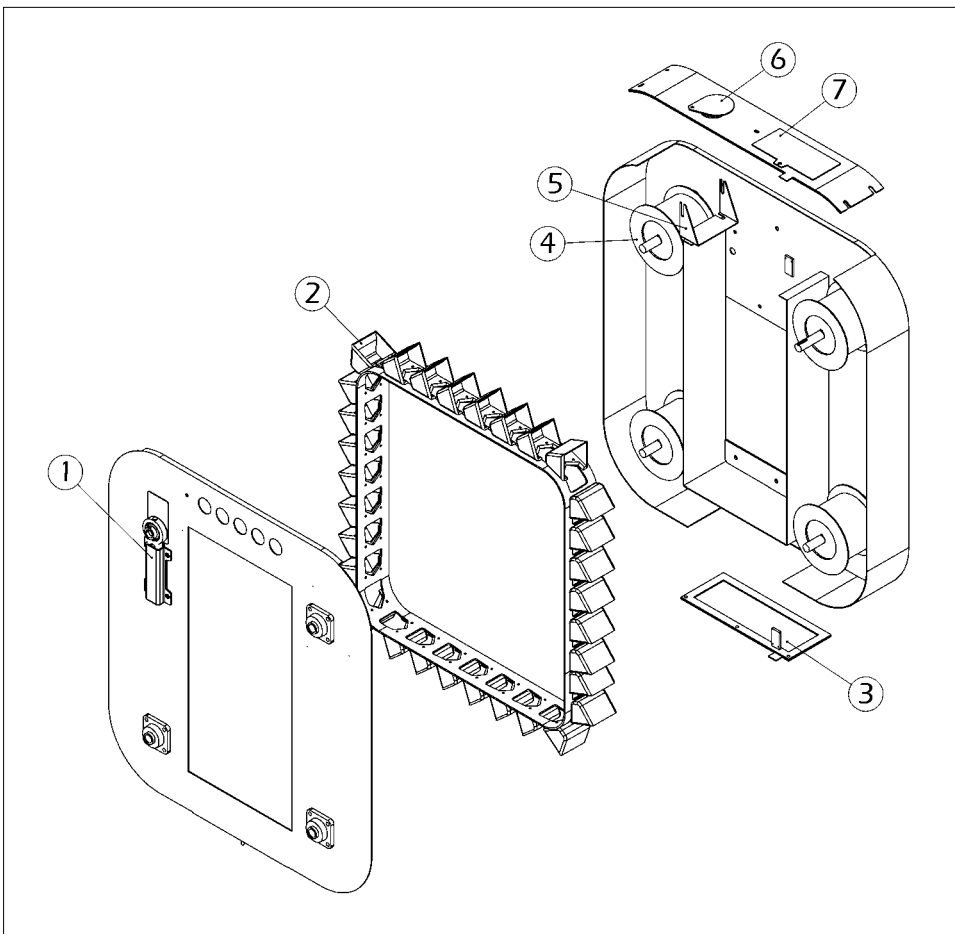

Fig. 3.8

1. Tension bearing
2. Elevator bucket
3. Bottom cover
4. Elevator roll
5. Abrasive support plate
6. Top cover air plate
7. Top cover air plate



General**3.12 Drive system**

The drive system is for moving the machine left or right. The drive rollers are operated with the joystick on the remote control box.

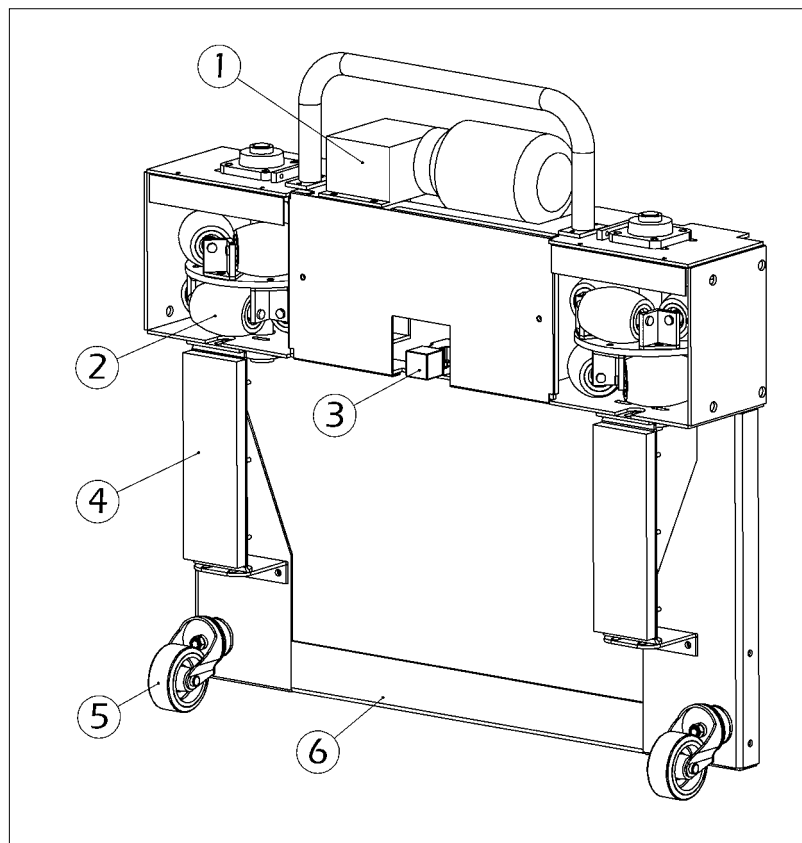

Fig. 3.9

- 1 Drive motor
- 2 Drive roller
- 3 Proximity switch
- 4 Magnet
- 5 Swivel castor
- 6 Bobbin frame

3.13 Abrasive sealing

The seal system comprises of four polyurethane seals to ensure that good sealing is maintained between the blast mouth and the work surface to be blasted. The seals are fixed in a seal box at the front of the blast opening of the cabinet and are clamped into place by nuts and straps.

To obtain access to seal system:

1. Make sure that the power unit is stopped.
2. Unscrew the nuts across the front of the seal box. This will untighten the straps holding the seals. Pull the seals out of the seal box.
3. Fit new seals. Retighten the straps with the nuts.
4. Warning: **Do not drop any nut in the blast mouth!**
5. Start up & commence work.

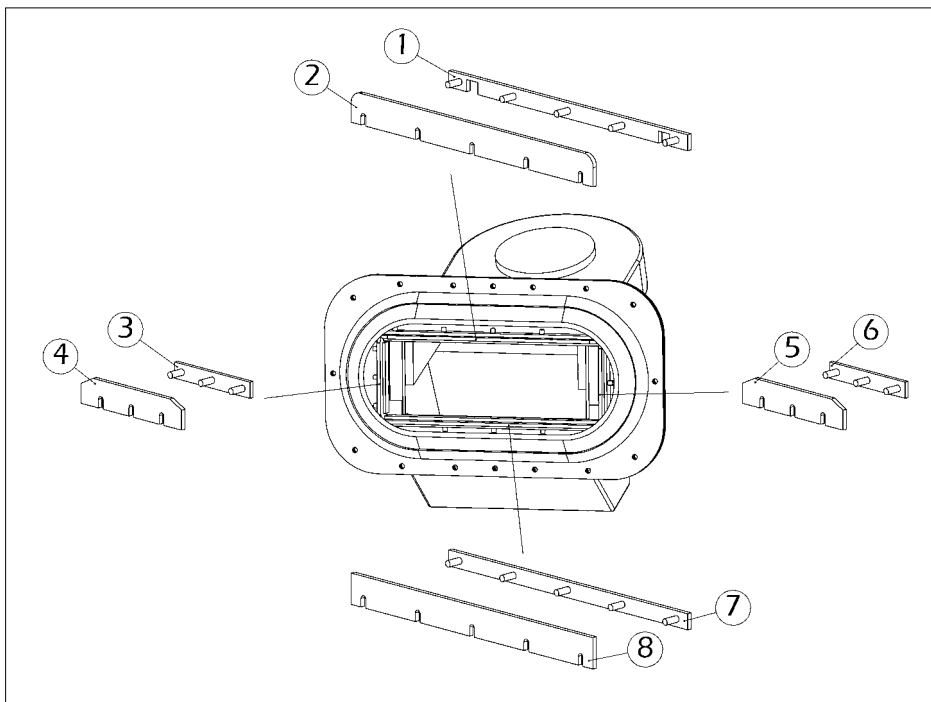

Fig. 3.10

- | | | | |
|---|-----------------------|---|-------------------------|
| 1 | Inner seal strap top | 5 | Inner seal right |
| 2 | Inner seal top | 6 | Inner seal strap right |
| 3 | Inner seal strap left | 7 | Inner seal strap bottom |
| 4 | Inner seal left | 8 | Inner seal bottom |

General

Mouth seal system:

The mouth seal is fixed to the blast mouth with nuts and bolts. To replace it, unscrew the nuts and remove the mouth seal. The brush is fixed to the blast mouth with nuts. Replace the brush if necessary.

Warning: **Do not drop any bolt or nut in the blast mouth!**

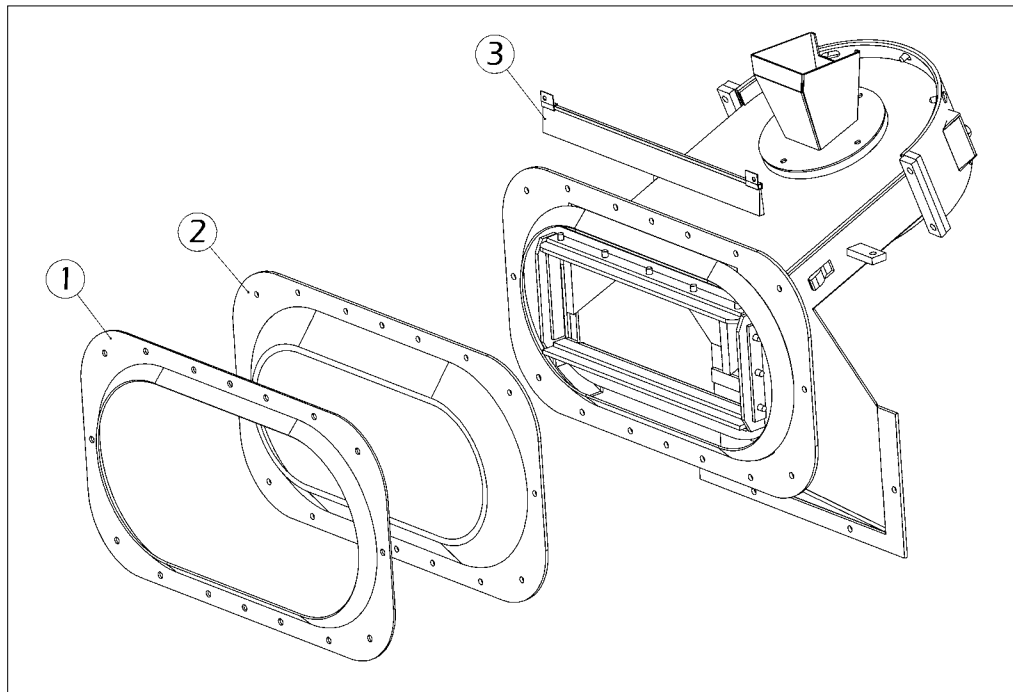

Fig. 3.11

- 1 Mouth seal outer plate
- 2 Mouth seal
- 3 Mouth seal airflow brush

3.14 Air suction and filter system

The air streaming through the complete system, created by an exhaust fan on the dust arrestor, has the following functions:

- Cooling of the blast wheels
- Cooling of the abrasive
- Transport of the abrasive
- Transport of dust through the system
- Separation of dust from the re-useable abrasive
- Transport of dust to the filter unit

Dust arrestor fan:

Motor output : 2.2 kW
Air throughput : 1200 m³/h

Dust hose:

Length : 30 m
Diameter : 130 mm

All connection points must be sealed carefully and the dust hose must be fixed with hose clamps!

The filter housing must be sealed properly and all sealings must be in good condition!

If dust leaves the filter unit instead of clean air, this is a sign that the filter cartridges are either damaged or not fixed correctly inside the filter chamber.

The air streams through the machine as follows:

- Air is sucked in at the blast head and carries along abrasive and dust.

General

- ❑ The air stream flows through the rebound plenum and carries along abrasive and dust. In doing so the air stream cools the abrasive and the housing walls.

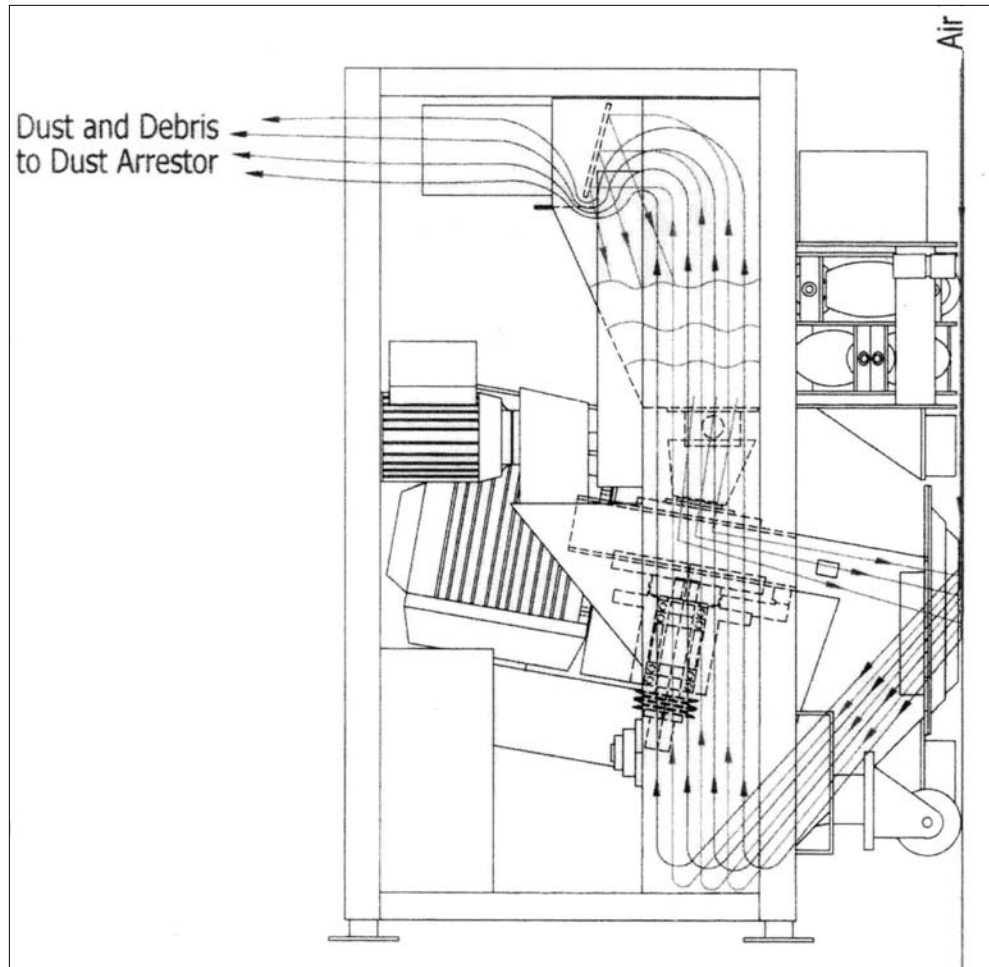

Fig. 3.12

- ❑ At the top of the elevator housing the air enters the separator, separates the fine dust from the abrasive and transports the dust to the outlet opening. The hopper door must be closed airtight in order to grant an optimum performance of the separator.
- ❑ The air stream then flows through the approx. 30 m (up to max. 90 m) long flexible dust hose taking dust and fine particles with it.
- ❑ The air stream now enters the filter chamber of the filter unit where the dust and the fine particles are separated from the air. The cleaned air is then fed into the environment again.

3

3.15 Abrasive media

In order to operate the **ISPC Blastrac/EBE** machine EBE 350 VH you need hardened (max. 45 Rockwell), spherical abrasive. The machine EBE 350 VH has been especially designed to be operated with **ISPC Blastrac/EBE** abrasive.

The **ISPC Blastrac/EBE** abrasive is of very high quality and owns the rebounding ability required for the efficient use of model EBE 350 VH. The selection of the abrasive is very important since this is the material to carry out the surface treatment.

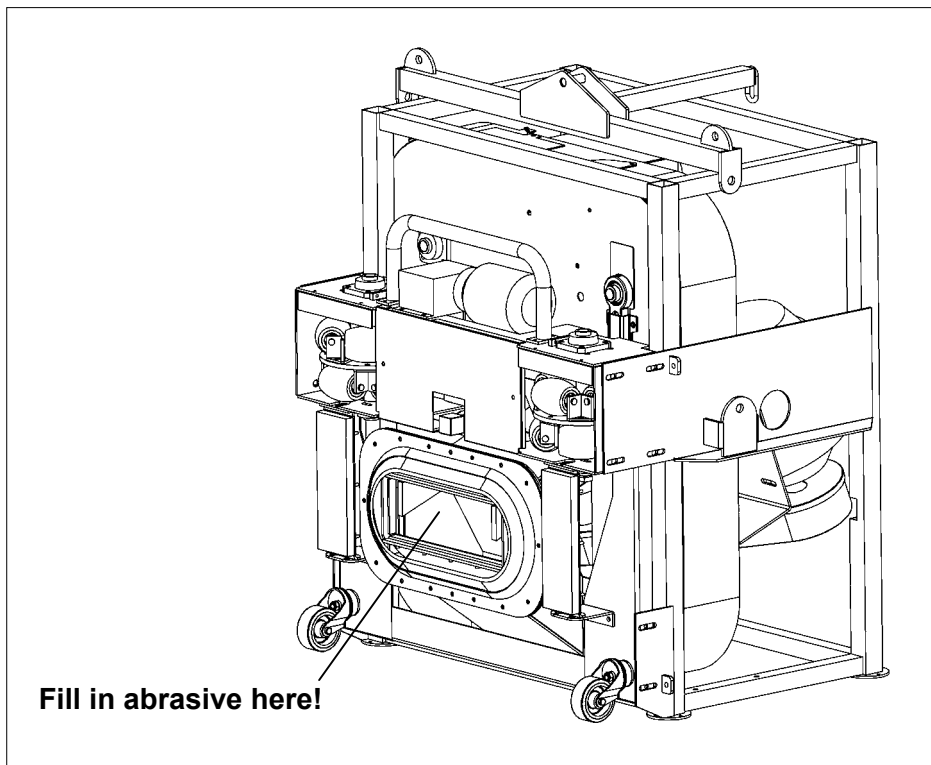

Fig. 3.13

General

Selection of abrasive

Abrasive shot S330 - S390 - S460:

Standard abrasive, suitable for about 50-60 % of all applications.

Applications:

- removes coatings with a thickness of 1-3 mm and cleaning of steel surfaces

Abrasive shot S330 - S390 - S460 with SG25 - SG18 - SG16:

For removal of coatings from steel surfaces mix approx. 25% shot with 75% grit. The type of the abrasive mix is depending on the profile requirements.

Applications:

- removes polyurethane coatings
- removes adhesive remnants
- removes rubber deposits
- penetrates coatings hard to remove



**Warning: never use abrasive harder than 45 Rockwell !
Otherwise the wear in the machine would increase
disproportionately.**

The effectiveness of the EBE 350 VH depends on the rebound effect, which ensures that the abrasive can be re-used.

Please take into account that the use of incorrect abrasive increases wear.

Our service engineers have the experience to select the appropriate abrasive for the individual cases of application.

Please consult our local **ISPC Blastrac/EBE** customer service department if you have any questions about the selection of the best abrasive for your blast cleaning work.

**3**

Contents Chapter 4

4.1 General notes

4.2 Transport

4.3 Operation conditions

4.4 Operation

4.5 Unit specifications



Transport

4.1 General notes



Before the machine is used for the first time, **ISPC Blastrac/EBE** authorised dealers offer a course to familiarise maintenance and operating personnel with all elements of the machine. We are not liable for damage caused by incorrect use of the machine by personnel not trained by **ISPC Blastrac/EBE**.

4.2 Transport

When transporting the machine proceeds in such a manner that damage due to the effects of the use of force or incorrect loading and unloading is avoided.

Remove the abrasive from the machine before it is transported. The machine may only be lifted by using the suspension eyelets. The weight and dimensions of the machine are shown in Chapter 1 "Technical data".

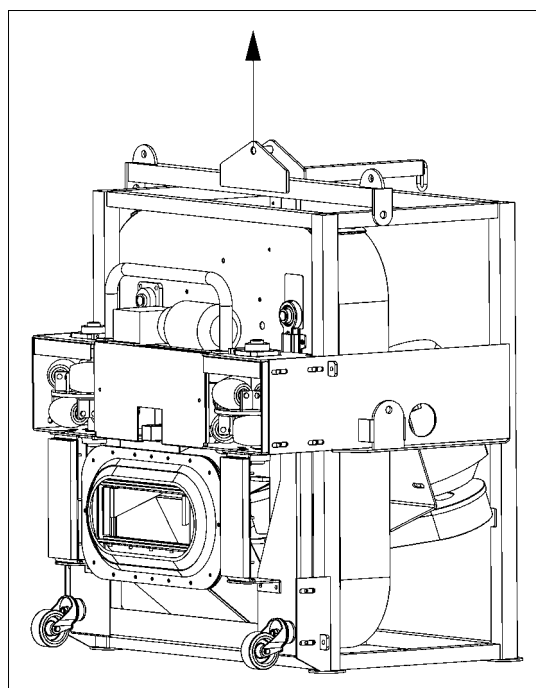

Fig. 4.1

The machine is to be transported after being separated into:

- Machine
- Filter unit
- General accessories

4.3 Operation conditions

Check the surface to be treated for loose parts. The surface must be swept if necessary. Make sure that the machine can travel over all inequalities on the surface. Small inequalities like weld seams are no barriers for the machine.

4.4 Operation

The machine is operated in accordance with the instructions given in Chapter 5 "Initial operation".

Whenever the machine is not used for blast cleaning, the abrasive valve must always be closed!



Please note that the illustrations are simplified.

4.5 Unit specifications

The main dimensions and unit specifications of the machine when assembled are shown in Chapter 1 "Technical data".



Contents Chapter 5

5.1 Preparations for initial operation

5.2 Initial operation

Initial operation

5.1 Preparations for initial operation

Before switching on make sure that all existing protective housings are mounted and that the filter unit is connected correctly.



All persons in the proximity of the machine must wear ear protectors, safety glasses with lateral protection as well as safety shoes. The operator is obliged to wear close-fitting protective clothing.



Handle all plugs, cables, hoses and operating devices with care. Avoid any contact with live wires.

Works on the electrical system must only be carried out by qualified specialists.

5 Check the surface to be treated for loose parts. The surface must be swept if necessary. Make sure that the machine can travel over all inequalities on the surface. Small inequalities like weld seams are no barriers for the machine.



Regular inspection is important in order to avoid downtimes. Carry out the following checks before any start-up:

- Check whether all machine parts are assembled safely and correctly.
- Check all screws and other fasteners for tight seat.
- Check the abrasive storage hopper, the feed spout and the blast wheel parts for foreign bodies and remove them.
- Check the blast wheel blades, impeller, control cage, liners and fastening screws for damages and wear.
Wear by abrasive will take place in the form of grooves along the blades from the center of the blast wheel outwards. Wear grooves are acceptable until 75% of the blade thickness has been worn away. When this point is reached, replace all blades as a set.
- Check seal system and brush seal for wear.

Initial operation

- ☑ Check the tightness of the hose connections and the condition of the hose to the filter.
- ☑ Make sure the dust container of the filter unit is empty.
- ☑ Check the separator parts for wear and defects. Remove foreign bodies and dust deposits in order to prevent the separator from being blocked.
- ☑ Check the electrical connections for dirt and foreign body deposits.
- ☑ Check the electrical motors for dirt and other contaminants.
- ☑ To fill the abrasive storage hopper, first switch on the bucket elevator. Fill approx. 40-50 kg of the selected abrasive (see Chapter 3.15) into the blast mouth opening of the blast cleaning machine. The bucket elevator will transport the abrasive to the storage hopper. The shot valve must be closed whilst doing this.

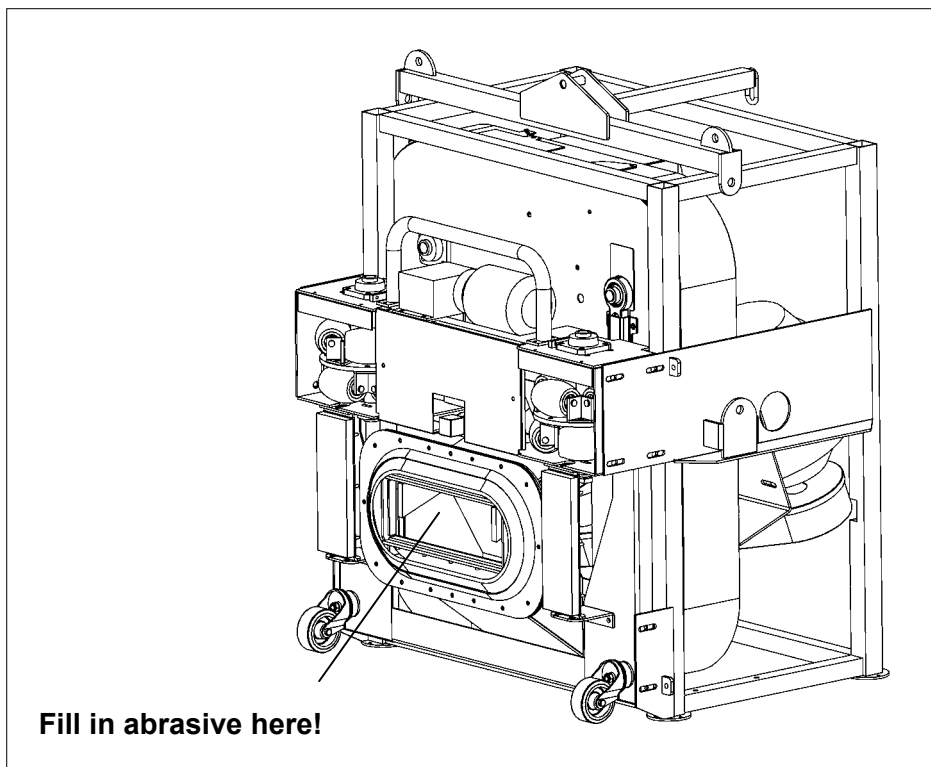

Fig. 5.1

- ☑ Check that the filter dust container has been emptied.

Initial operation



Before start-up the operating personnel must be familiar with the safety regulations given in this manual.

- The blast cleaning machine needs to be suspended from a lifting system such as a mobile crane, dockside crane or system built lifting beam.
- Connect the remote control cable to the socket on the blast cleaning machine.
- Check the main power cable and the dust hose for damage. Replace or repair all damaged parts before starting the machine.
- Connect the blast cleaning machine and the filter unit with the dust hose. Use hose clamps at the connections.
- Connect the supply cable of the blast cleaning machine with the filter unit. Connect the electric cable of the filter unit with the site supply (400/480V, 50/60 Hz, 32 A).

5

5.2 Initial operation



All persons in the proximity of the machine must wear ear protectors, safety glasses with lateral protection as well as safety shoes. The operator is obliged to wear close-fitting protective clothing.

The start of the blast cleaning machine and the filter unit is effected in the following sequence:

1 Switching on the filter unit

- Main switch of the filter unit "ON".
- Compressor "ON".
- Fan "ON".
- Pulsator "ON".
- Check the turning direction of the filter and compressor motor. The correct turning direction is indicated by the arrow on the belt guard.

Initial operation

2 Initial operation of the blast-cleaning machine

- Check that the shot valve is closed.
- Check that the emergency shutdown switch on the remote control box is not actuated.
- Switch the main switch of the machine to "ON". The control lamp "Power" on the control box lights up.
- Press the push button "Elevator ON".
- Check the level of abrasive in the storage hopper. Refill if necessary (see fig. 5.1).
- By means of the lifting device, lift the machine to the point where the machine needs to commence its blast cleaning operation. Blast cleaning is carried out in a down mode.
- When the machine gets within 50 mm of the work surface, the magnets will pull the machine to the work surface. The machine is now in a working position.
- Press the push button "Main blast ON". The blast wheel motor is started.
- Observe the ammeter in order to check the power consumption of the blast wheel motor. The motor requires a lot of power (starting current) when it is started until it reaches its maximum speed.
- Once the blast wheel has reached its rated speed the current drops to approx. 8 A no-load consumption.
- If the ammeter indicates more than the normal current value after 10 seconds, interrupt the power supply and find the cause.
- If the ammeter indicates high load consumption after having reached the idle-running speed, the shot valve may be partially open or there may be another disturbance.
- Find out the cause of the disturbance and, if necessary, contact your **ISPC Blastrac/EBE** customer service engineer.

Initial operation

- ❑ By means of the remote control, check the movement of the machine. Blast cleaning is carried out in a down mode.

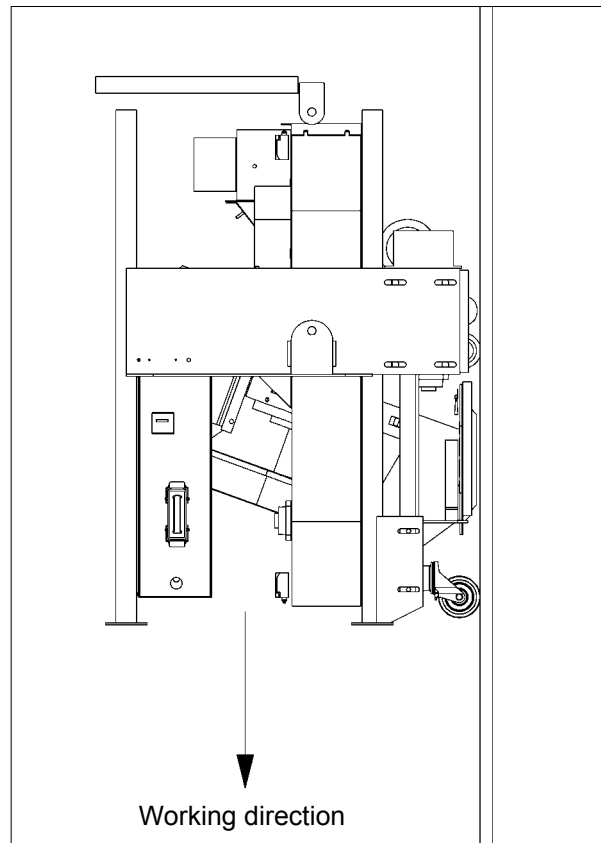

Fig. 5.2

- ❑ When the machine is travelling, push the abrasive control button “+” to operate the valve. Observe the ammeter. Adjust the amperage by pushing the shot control buttons “+” and “-“ until the ammeter indicates the full load amperage (max. 20 A).
- ❑ An indication exceeding the full load value means overloading of the motor, whereas an indication below the full load value shows that there is not enough abrasive fed to the blast wheel. If necessary refill the machine with abrasive.
- ❑ After having blasted approx. 2 m close the abrasive shot valve, stop the machine and check the blasted surface.
- ❑ If the blast pattern is irregular it may be necessary to re-adjust the blast pattern (see Chapter 7.5 “Setting the blast pattern”) or select another travel speed for the machine.

Initial operation

- ❑ Control the speed of movement in a vertical mode (down) by means of the remote control, to such an extent that the blast cleaning quality is achieved, i.e. slow movement = better quality. This applies only when the optional winch is fitted, otherwise the mobile crane operator controls the speed of the machine.
- ❑ Steer the machine left or right by the remote control to maintain a good blast cleaning path.
- ❑ At the end of the blast cleaning path, switch off the shot control valve (“-“). By means of the left/right steering control, move the machine left or right to the next area to be blast cleaned. At the same time the lifting point above the machine (crane) has to move a similar amount. Blast cleaning operation can then continue.
- ❑ Continue operations above until the total area to be blast cleaned is completed.

When the blast head is lifted from the work surface, abrasive escapes from the sides of the blast head at high speed. If the machine is moved with the blast head raised, the abrasive shot valve must be closed and the blast motor must be off.



Alter the travel direction only after having closed the shot valve.



The dust container of the filter unit must be emptied regularly.



Contents Chapter 6

- 6.1 Operation
- 6.2 Switching-off the machine
- 6.3 Removing the hoisting cable
- 6.4 What to do if a fault occurs
- 6.5 Safety shutdown
- 6.6 Restarting after a fault
- 6.7 Measures before and after long standstills



Operation

6.1 Operation

Normal start-up and operation of the blast machine EBE 350 VH is no different from the procedure described in Chapter 5 “Initial operation”.

Carry out blasting in parallel tracks in such a way that the dust hose and electric cable do not become twisted.

The selection of the correct advancing speed of the blast machine is important for a good blast result. In the case that the surface has different characteristics (e.g. different hardness or different coating thicknesses), a uniform blast result can be achieved by varying the advancing speed during blast cleaning.

6.2 Switching-off the machine

- Shut off the abrasive supply by pushing the “Shot control -“ button on the remote control box until the shot valve is completely closed.
- Press the push button "Main blast OFF" on the remote control box. This switches off the blast wheel motor.
- Press the push button "Elevator OFF" on the main box at the rear of the blast cleaning machine. This switches off the elevator motor.
- Set the main switch on the main box at the rear of the blast cleaning machine to "OFF".
- After several minutes press the push buttons "Compressor OFF", “Fan OFF” and "Pulsator OFF" on the filter unit.
- Set the main switch of the filter unit to "OFF".

Make sure that all turning machine parts have come to standstill before any inspection or maintenance works are started.



When the **ISPC Blastrac/EBE** blast cleaning machine is put out of operation for a longer period of time, pull out the mains plug and cover the machine with a plastic foil.

Before taking the machine out of operation for a longer period of time, the abrasive should be removed from the machine. This is achieved by lifting the machine approx. one meter above ground level, opening the elevator bottom cover (see fig. 3.8) and emptying the abrasive in a container.

The abrasive in the abrasive storage hopper can be emptied in a container by removing the grit funnel (see fig. 7.1) and opening the shot valve by pushing the “Shot control +” button on the remote control box (power is required - see Chapter 5.2).

After the abrasive storage hopper has been emptied, close the shot valve again before taking the power off.

Note: If the abrasive is not removed there is a possibility that through condensation in the atmosphere the abrasive will congeal, which can cause great damage to the machine if it is attempted to be used in this condition.

6

6.3 Removing the hoisting cable

IMPORTANT: With all weight removed from the hoisting cable, remove the cable hook from the suspension point and lower to ground level with an assistant who must pull out all loose wire to the side and maintain pressure on the wire, to ensure that it is coiled evenly on the winch drum. Pull in all loose wire.



Operation

6.4 What to do if a fault occurs

Irrespective of the following information, the local safety regulations are valid in any case for the operation of the machine.



First put the machine to its **Safety off position**. After that start looking for the defect. See Chapter 9 “Fault diagnosis”.

6.5 Safety shutdown



The machine must be put to its safety off position before starting repair works. See Chapter 2 “Safety instructions”.

6.6 Restarting after a fault

See Chapter 5 “Initial operation”.



All persons in the proximity of the machine must wear safety glasses with lateral protection as well as safety shoes. The operator is obliged to wear close-fitting protective clothing.

6.7 Measures before and after long standstills

Standstill of the machine for a maximum of 3 months.

Before a long standstill period

Switch off the machine (see Chapter 6.4).

Protect the electric motors from moisture, heat, dust and shocks.

Clean the machine and cover it with a plastic foil.

Preserve bright parts of the machine and power pack with Tectyl 506, for example, or a similar preservative.

**After a long standstill period**

See Chapter 5 “Initial operation”.



Contents Chapter 7

- 7.1 Recommendations
- 7.2 Maintenance and inspection list
- 7.3 Repairing
- 7.4 The blast pattern
- 7.5 Setting the blast pattern
- 7.6 Setting the control cage
- 7.7 Wear parts
- 7.8 Blastwheel blades & Impeller replacement
- 7.9 Changing the liners



Maintenance

7.1 Recommendations



With maintenance and inspection works, please observe Chapter 2 "**Safety instructions**".

Failures due to inadequate or incorrect maintenance may generate very **high repair costs** and long standstill periods of the machine. **Regular** maintenance is therefore imperative.

Operational safety and service life of the machine depend, among other things, on proper maintenance.

The following table shows recommendations about time, inspection and maintenance for the normal use of the machine.

The time indications are based on uninterrupted operation. When the indicated number of working hours is not achieved during the corresponding period, the period can be extended. However a full overhaul must be carried out at least once a year.

Due to different working conditions it cannot be foreseen how frequently inspections for wear checking's, inspection, maintenance and repair works ought to be carried out. Prepare a suitable inspection schedule considering your own working conditions.

Our specialists will be happy to assist you with more advice.

7



Prior to any repair works on the machine and its drives, secure the machine against unintentional switching-on. Put the machine to its safety off position.



The supplier's operating and maintenance instructions should also be followed during service and maintenance.

Maintenance

7.2 Maintenance and inspection list

Operating hours/ time period	Inspection points, maintenance instructions
12 h after repairing	Check the efficiency of all safety devices. Check all accessible screw connections for tight seat.
every 3 h	Check whether there is any foreign matter in the hopper, the shot valve housing or in the blast wheel unit. Check blast wheel, liners and fasteners for wear and damage. Check the seal systems for wear. Check the electric connections for sediments of dirt or foreign bodies. Check the electric motors for dirt and other contaminants.
daily and prior to starting work	Check the hose connections for tightness and fixed seat. Check the hose to the filter for damages. Make sure that the dust container of the filter is emptied. Check blast wheel, liners and fasteners for wear and damage. Check the separator parts for wear and defects. Remove foreign bodies and dust deposits. Check the level of abrasive in the storage hopper. Top up if necessary. Check all connections of the electric cables for fixed seat, and check the cables for damage. Check the electric motors and connections for dirt and other contaminants.
annually	Full overhaul and cleaning of the complete machine.



Maintenance

7.3 Repairing



As already mentioned in Chapter 5 “Initial operation” we recommend to execute the first repair works on the machine with the help of **ISPC Blastrac/EBE** personnel. With this your maintenance personnel gets the opportunity to be trained intensely.

Only those repair works are described which occur within the context of maintenance or which are required to replace wear parts.

If you replace parts yourself for specific reasons, the following instructions and work sequence have to be observed.



You should also stock all spare or wear parts that cannot be supplied quickly. As a rule, production standstill periods are more expensive than the cost for the corresponding spare part.

Screws that have been removed must be replaced with those of the same quality (strength, material) and design.



Prior to any repair works on the machine and its drives, secure the machine against unintentional switching-on. Pull out the mains plug in order to do this.

7.4 The blast pattern

Abrasive leaving the blast wheel blades is not thrown in all directions. Scatter is restricted to an angle of about 80°. This is achieved through the use of a control cage, which surrounds the impeller. The position of the window in the control cage determines the blast pattern.

Correct adjustment of the control cage and thus of the blast pattern is the most important factor for optimum working with the EBE 350 VH blast cleaning machine.

Incorrect adjustment of the control cage results in very high wear and premature blasting-through of the liners in the blast wheel housing, as well as reduced blasting performance and a possible loss of the rebound energy of the abrasive.

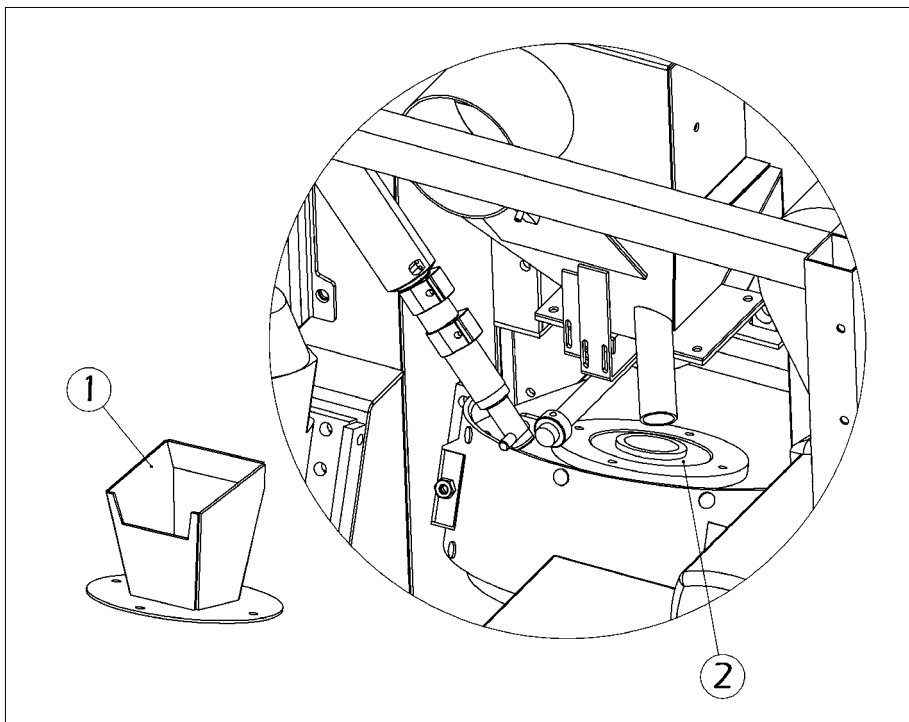
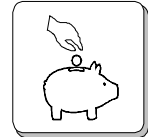

Fig. 7.1

- 1 Grit funnel
- 2 Control cage

The adjustment is effected by loosening the grit funnel (pos.1) and turning of the control cage (pos.2).

Maintenance



Every time the control cage is replaced, the thread of the blast wheel fastening screw should be checked. Make sure that this screw will be tightened correctly. In addition, absolute care must be taken to clean the thread from dust and abrasive.

After each blast wheel repair work switch on the blast wheel motor for a short period (without feeding abrasive) in order to find out whether the rotating parts turn freely and without vibration. After that, the blast cleaning procedure can be continued.



The blast wheel motor is designed for a long service life. Damages to the blast wheel motor can be detected by unusual noises or functional failure of the electric motor. In this case notify our service department.

7.5 Setting the blast pattern

In order to obtain a uniform and perfect blast pattern on the surfaces to be treated, the correct adjustment of the blast pattern is of utmost importance.



Prior to any repair works on the machine and its drives, secure the machine against unintentional switching-on. Put the machine to its safety off position.

An incorrect adjustment of the blast pattern results in:

- Uneven cleaning (shadows on the right or left hand side).
- Extremely high wear of the blast wheel, blades, impellor, control cage and liners.

The following 4 factors affect the blast pattern:

Turning direction of the blast wheels:

- The turning direction of the blast wheel must correspond to the instructions on the housing (arrow indicating the turning direction).

Worn blast wheel parts:

- With increased wear of the blast wheel, blades, impeller and control cage, the blast pattern will change.

Size of abrasive:

- The size of the abrasive affects the blast pattern. With every exchange of abrasive, the blast pattern must be re-adjusted.

Position of the control cage:

- The correct adjustment of the control cage is the most important factor to obtain an optimum blast pattern. The control cage has a lateral window. The position of the window determines where the abrasive is fed onto the blast wheel blades and where it hits the surface to be treated.
- After each exchange of blast wheel parts, the adjustment of the control cage must be checked and re-adjusted by creating a blast pattern. The same applies for blasting on another type of surface.



Maintenance

7.6 Setting the control cage

The adjustment is effected by loosening the cage clamps and turning the control cage in the suitable direction. The cast groove on the control cage shows the central position of the control cage opening. The following adjustment standard value is valid: the control cage opening is approximately opposite to the throwing angle. The abrasive grain size plays an important role here. Different types of abrasive have different throwing characteristics due to their different weights and frictional resistance. This means that you must never use different types of abrasive at the same time.



Prior to any repair works on the machine and its drives, secure the machine against unintentional switching-on. Put the machine to its safety off position.



After fitting new spare parts always create a blast pattern in order to check the blasting direction. This is the only way to grant economical work and to avoid unnecessary wear and repair costs.

The adjustment can be carried out as follows:

- Determine the notch which indicates the centre of the window edges.
- If the blast wheel is turning counter-clockwise, set the notch of the control cage to imaginary 9.30 of a dial (fig. 7.2).

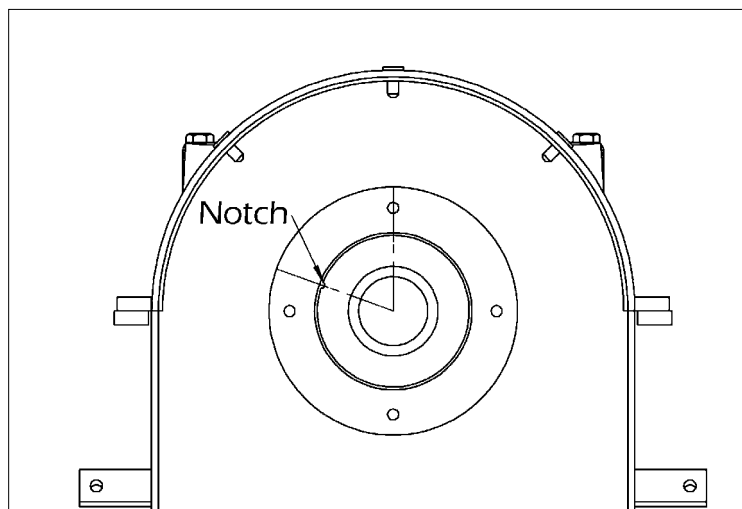

Fig. 7.2

Maintenance

- ❑ Move the blast head of the blast machine onto a 5-8 mm thick steel plate and blast for 15 seconds at full amperage without moving the machine from the spot.
- ❑ Stop the abrasive flow and move the machine until the blasted area is accessible. With both hands, **carefully** feel the temperature of the blasted area. You will find the hot spot on the blasted surface where the machine has developed the highest blast cleaning intensity.
- ❑ An even temperature from left to right indicates that the control cage is correctly positioned.
- ❑ Looking from the front side of the machine onto the control cage: If the left side of the blasted area is warmer, turn the notch of the control cage clockwise for 3-6 mm. If the right side is warmer, turn the notch of the control cage anti-clockwise for 3-6 mm.
- ❑ This process to be repeated until an even temperature across the blast pattern is achieved.
- ❑ Now the blasting procedure can be started. The blast pattern will change with an increased wear of the blast wheel, blades, impellor and control cage, and when the size of the employed abrasive is changed.

Never loosen the grit funnel or try to adjust the control cage when the machine is in operation.



Maintenance

7.7 Wear parts

The blast wheel parts

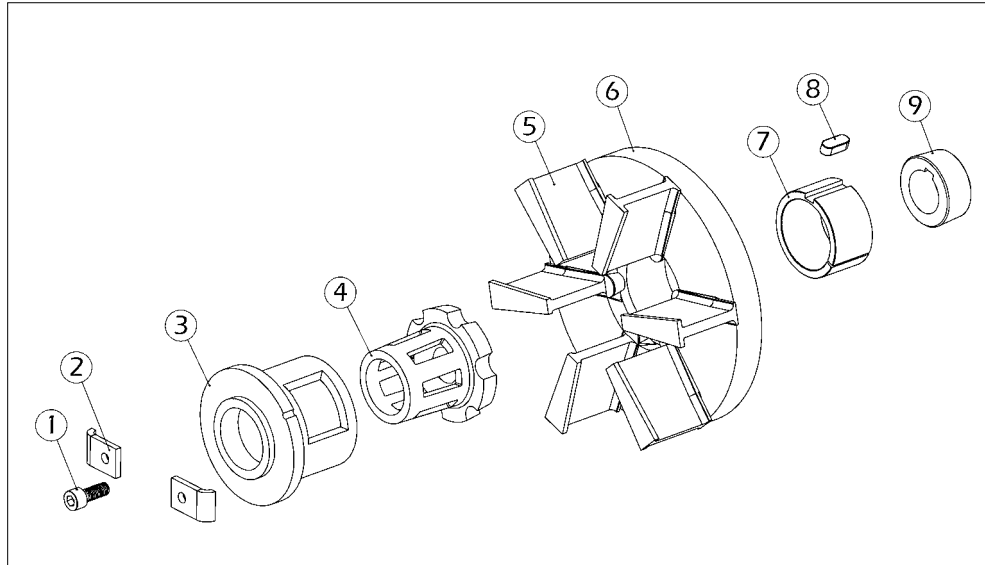

Fig. 7.3

- 1 Impeller bolt
- 2 Control cage clamp
- 3 Control cage
- 4 Impeller
- 5 Blades (set of 6)
- 6 Blast wheel
- 7 Taper lock adapter
- 8 Parallel key
- 9 Taper lock bush



The liners

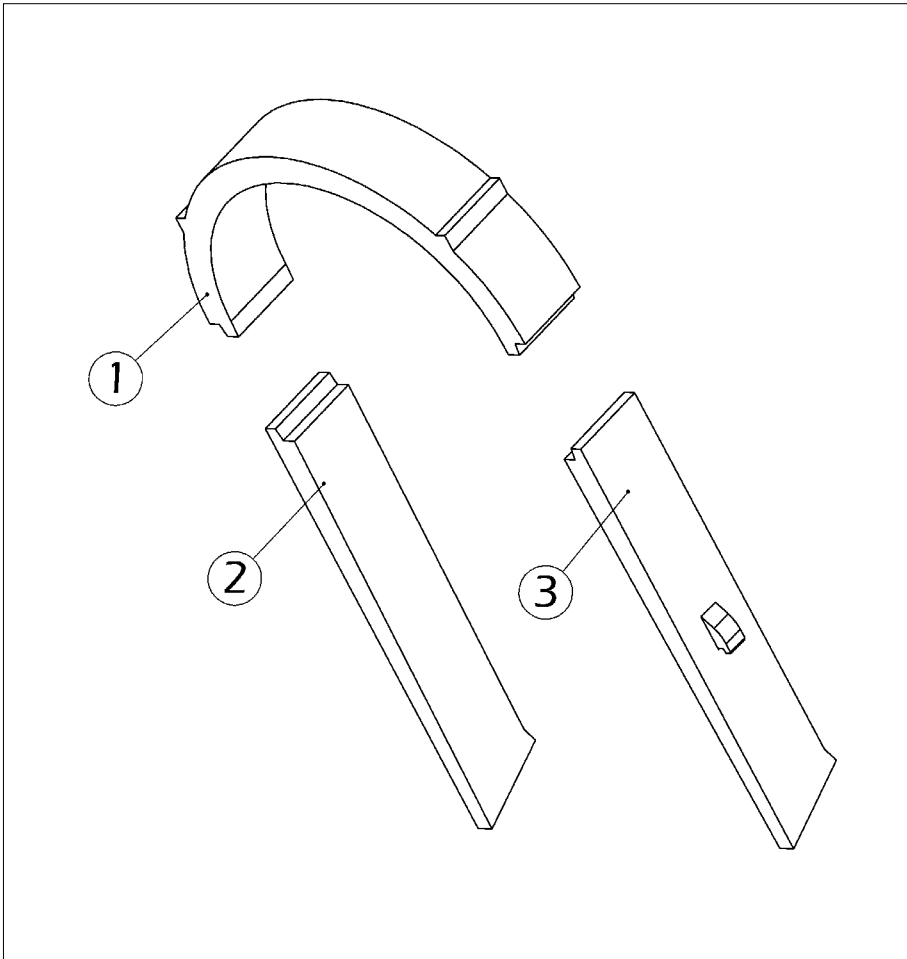

Fig. 7.4

- 1 Top liner
- 2 Right liner
- 3 Left liner

Maintenance

7.8 Blastwheel blades & Impeller replacement

During operation the blast wheel blades and the impeller will wear.

To replace worn components:

- Make sure the power unit is stopped and the main electricity supply disconnected.
- Remove the bolts securing the grit funnel (fig. 7.1) and remove the grit funnel from the machine.
- Unscrew the impeller bolt and remove the impeller.
- Clean the blast wheel and the blades with air.
- Through the opening at the front of the blast housing: use a wooden or brass drift to tap out all six blades from the blast wheel towards the centre of the blast wheel.
- Clean the blast wheel thoroughly to make sure that the new blades and impeller will fit well and to avoid any imbalance of the blast wheel.
- Replace the blades with six new ones and re-assemble the machine in reverse order. Note: blast wheel blades must be replaced as a set. Replacing only some of the blades can cause imbalance of the blast wheel.

7.9 Changing the liners

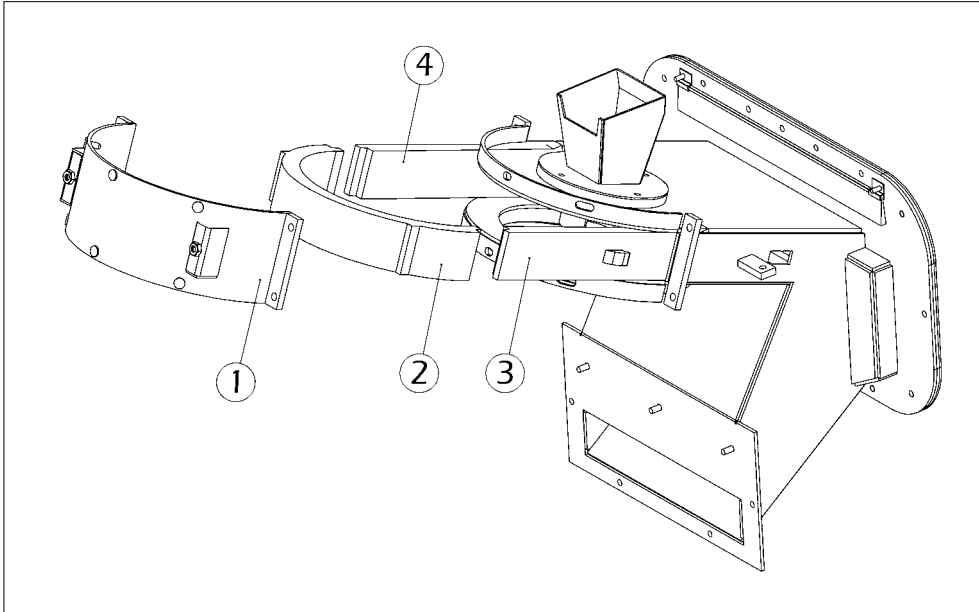

Fig. 7.5

- 1 Top liner cover
- 2 Top liner
- 3 Left liner
- 4 Right liner

- Unscrew the top liner cover and remove it.
- Take the top liner out of the blast housing.
- Loosen the fastening screws securing the left and the right-hand liners and take the side liners out of the blast housing at the front of the blast housing.
- Replace all worn items. Clean the liners and the inside of the blast housing thoroughly. Re-assemble the machine in reverse order, using kit between the top liner and the side liners, and between the top liner and the front and rear plates of the blast housing. Make sure that the top liner sits close at the edges of the side liners.

Contents Chapter 8

8.1 Circuit diagrams

Electrical systems

8.1 Circuit diagrams

PROJECT

Client :USF BLASTRAC / EBE
 Name :Blastmachine EBE 350 VH/
 UNI

Particulars:

SUPPLIER

Draw. number :350-9110-VH/UNI
 Order number :

Supplier : USF BLASTRAC / EBE
 Contact :
 Telephone : +31(0)30-6018866
 Telefax : +31(0)30-6018333
 Email : info@usfebe.nl

DATA

Arch. number :PJ02.01745T1B
 Calc. number :
 Status :As built

Start of project :18.07.2002
 Latest change :14.08.2003 (HLU)

Highest page number : 16
 Number of pages : 16

Change	Date	Name	Status	As built	USF BLASTRAC / EBE Blastmachine EBE 350 VH/ UNI		Front page	Arch. nr. PJ02.01745T1B	Draw. nr. 350-9110-VH/UNI	Pages 16	Page 1

Wire color:

Main current:

L1 -Black
 L2 -Black
 L3 -Black
 PE / ⊕ -Yellow / Green

Control current alternating current (AC)

Phase -White
 Hook-up wire -White
 Zero -White

Control current direct voltage (DC)

(+) -Dark blue
 Hook-up wire -Dark blue
 (-) -Grey

Potential free:

Potential free -Orange

Symbol code explanation:

DP 5 Q 1

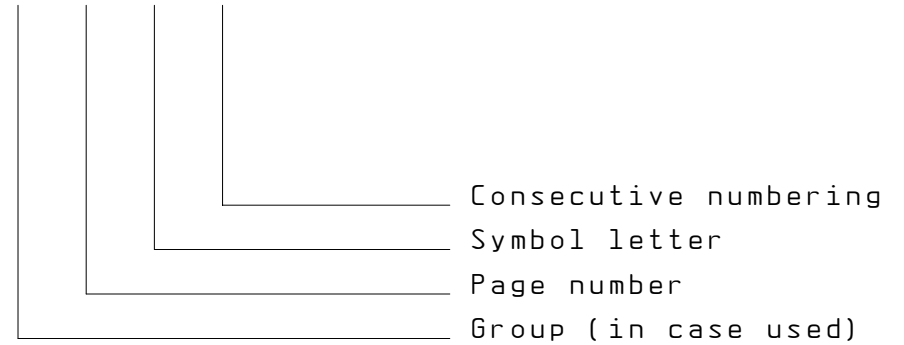

Archive number explanation:

PJ01.01234T1A

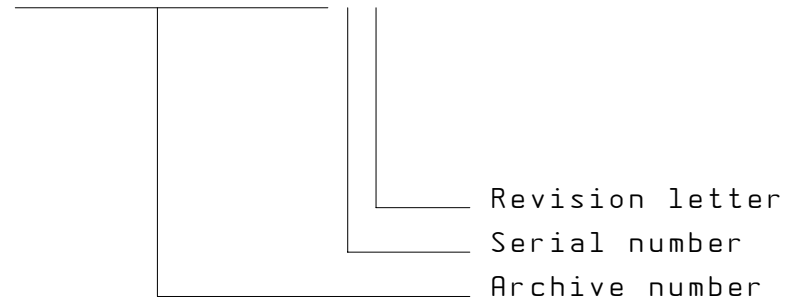

Change	Date	Name	Status	As built	UNI		Explanations	Arch. nr.	PJ02.01745T1B	=	
								Draw. nr.	350-9110-VH/UNI	Pages	16

0	1	2	3	4	5	6	7	8	9
		Pushbutton NO / NC			Pressure switch NO / NC		Pilot light		Main switch
		Rotary switch NO / NC			Level switch NO / NC		Horn		Fuses load divider
		Contact NO / NC		Relay		Valve		Diode module	
		Contact NO Cut-in delayed		Relay Drop-out delayed		Transformer		Resistance	
		Contact NC Cut-in delayed		Relay Cut-in delayed		Direct voltage supply		Motor safety switch	
		Contact NO Drop-out delayed		Relay Impulse		Terminal clamps			
		Contact NC Drop-out delayed		Ammeter		Fuses			
		Emergency stop NC		Voltmeter		Fuse + led			
		Contact NO / NC Thermal		Working hour counter		Earth-leakage switch Earth-leakage protection			
		Key switch NO / NC		Current coil		Installation automatic Short-circuit and overcurrent protection			
		Thermostat NO / NC		Engine		Autotransformer			

Start	18.07.2002	USF BLASTRAC / EBE Blastmaschine EBE 350 VH/ UNI		Symbol explanation	Arch. nr.	PJ02.01745T1B	
Eng.	RJO				Draw. nr.	350-9110-VH/UNI	
Print	14.08.2003				Pages	16	Page
Change	Date	Name	Status	As built			

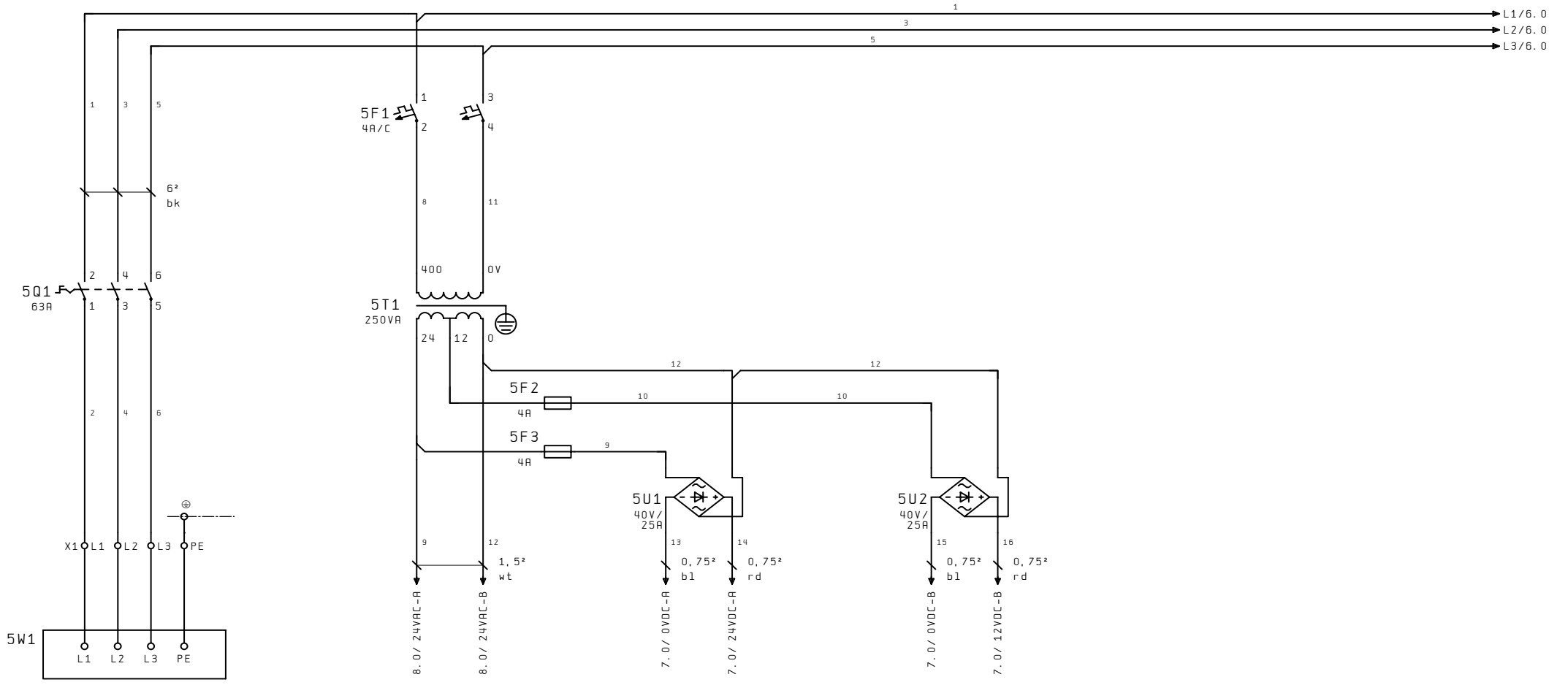

Supply
480V 60Hz.

Supply
24Vac.

Supply
24Vdc.

Supply
12Vdc.

Start	18.07.2002	USF BLASTRAC / EBE Blastmachine EBE 350 VH/ UNI	Main-voltage	Arch. nr.	PJ02.01745T1B		=	
Eng.	RJO			Draw. nr.	350-9110-VH/UNI		Pages	16
Print	14.08.2003			Page	5			
Change	Date	Name	Status	As built				

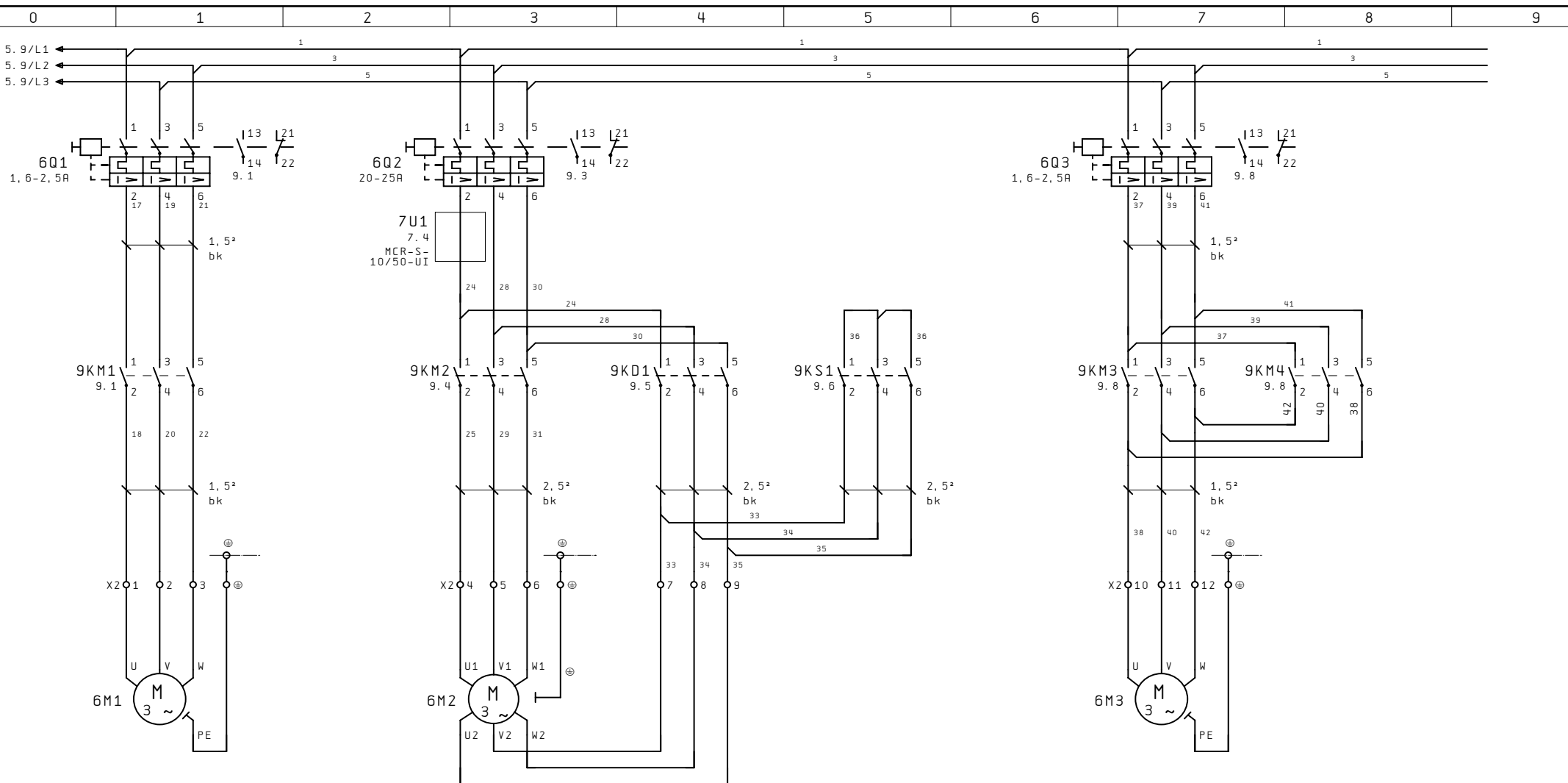

Elevator motor

Blast motor

Traverse motor

Start	18.07.2002	USF BLASTRAC / EBE Blastmaschine EBE 350 VH/ UNI	Main-voltage	Arch. nr.	PJ02.01745T1B		=	
Eng.	RJO			Draw. nr.	350-9110-VH/UNI		Pages	16
Print	14.08.2003					Page	6	
Change	Date	Name	Status	As built				

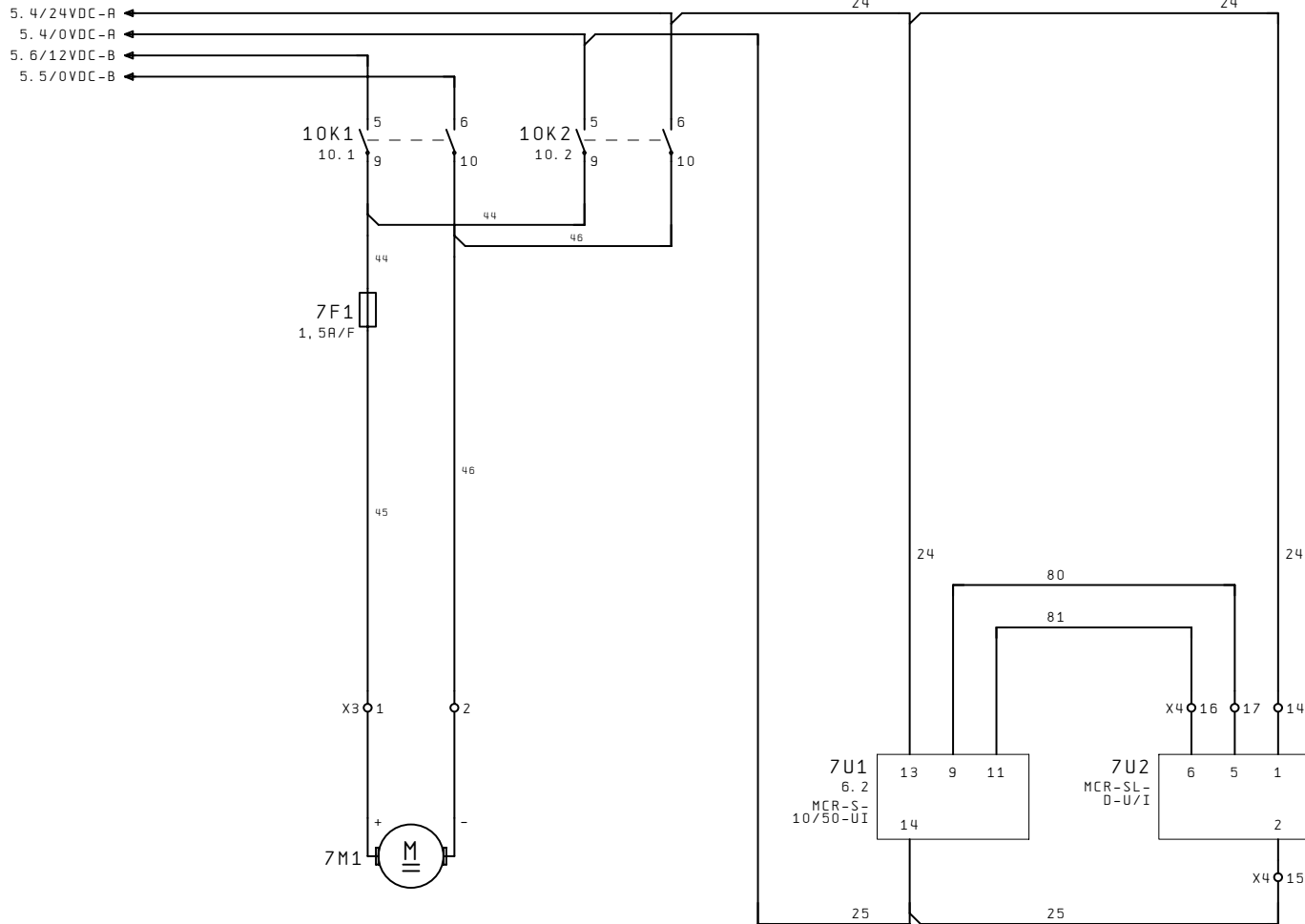

Shotvalve actuator

			Start	18.07.2002	USF BLASTRAC / EBE Blastmaschine EBE 350 VH/ UNI		Main-voltage	Arch. nr.	PJ02.01745T1B		=			
			Eng.	RJO				Draw. nr.	350-9110-VH/UNI		Pages	16	Page	7
Change	Date	Name	Status	As built										

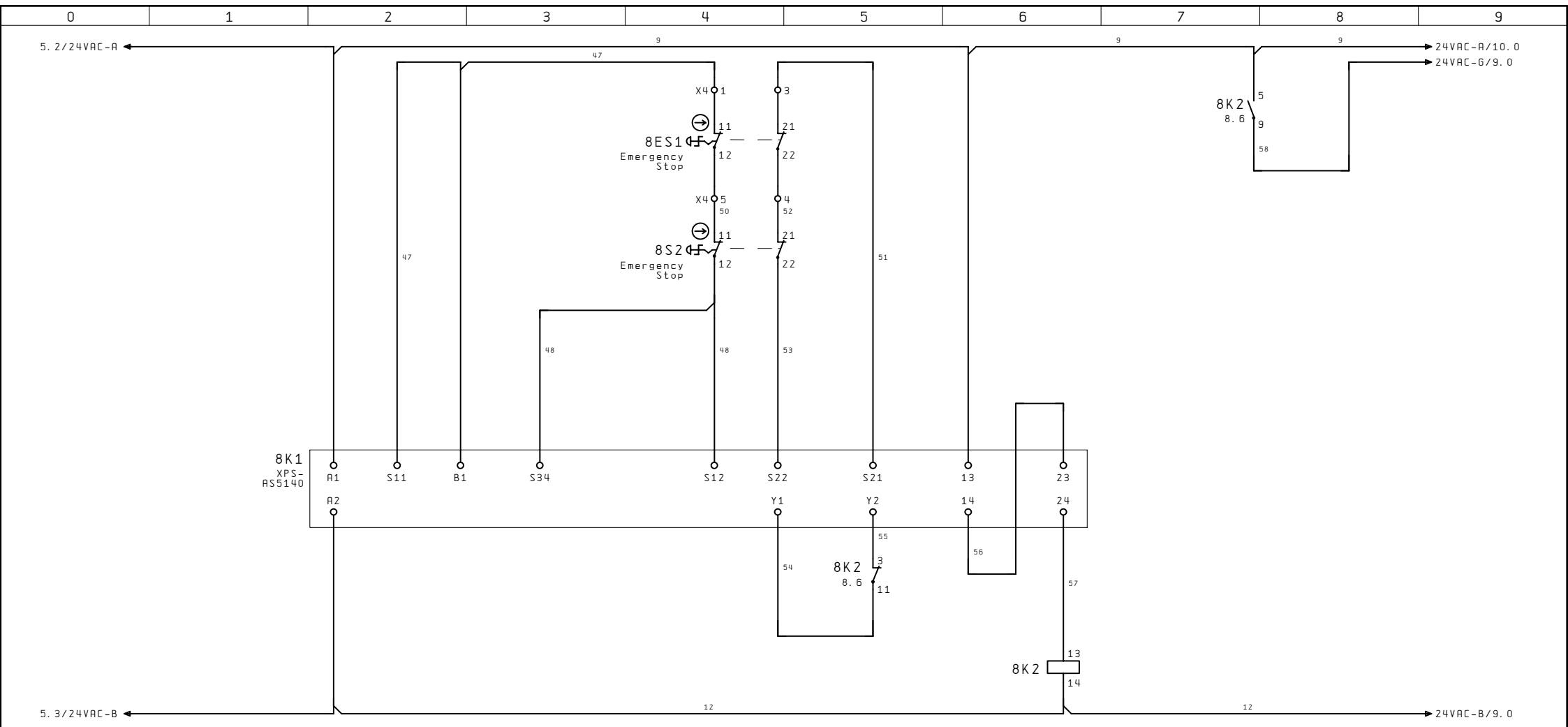

- 5 9 8.7
- 6 10
- 3 11 8.5
- 4 12

Change	Date	Name	Status	As built	Start	18.07.2002	USF BLASTRAC / EBE Blastmachine EBE 350 VH/ UNI		Control-voltage	Arch. nr.	PJ02.01745T1B		=		
				Eng.	RJO	Draw. nr.				350-9110-VH/UNI		Pages	16	Page	8
				Print	14.08.2003										

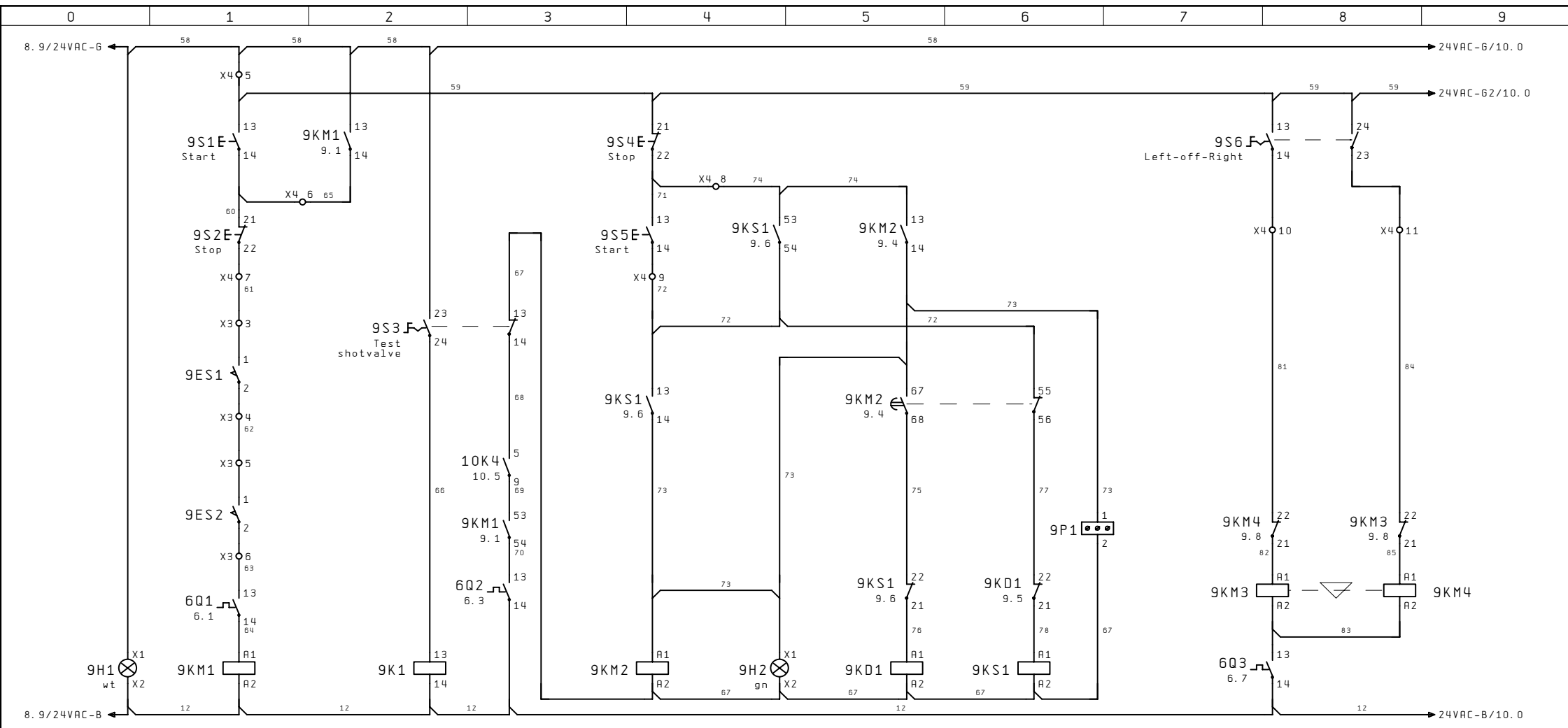

Control power on Elevator motor Shotvalve test Blast motor Delta relay Star relay Hour counter Left Right

- | | | | | | | |
|--------------|--------------|--------------|---------------|--------------|--------------|--------------|
| 1 -> 2 6.1 | 5 -> 9 10.0 | 1 -> 2 6.3 | 1 -> 2 6.4 | 1 -> 2 6.5 | 1 -> 2 6.7 | 1 -> 2 6.8 |
| 3 -> 4 6.1 | 6 -> 10 | 3 -> 4 6.3 | 3 -> 4 6.4 | 3 -> 4 6.5 | 3 -> 4 6.7 | 3 -> 4 6.8 |
| 5 -> 6 6.1 | 3 -> 11 10.3 | 5 -> 6 6.3 | 5 -> 6 6.4 | 5 -> 6 6.5 | 5 -> 6 6.7 | 5 -> 6 6.8 |
| 13 -> 14 9.2 | 4 -> 12 | 13 -> 14 9.5 | 21 -> 22 9.6 | 13 -> 14 9.4 | 21 -> 22 9.8 | 21 -> 22 9.8 |
| 21 -> 22 | | 55 -> 56 9.6 | 53 -> 54 10.1 | 21 -> 22 9.5 | | |
| 53 -> 54 9.3 | | 67 -> 68 9.5 | 61 -> 62 10.3 | 53 -> 54 9.4 | | |
| 61 -> 62 | | | | | | |

Start	18.07.2002	USF BLASTRAC / EBE Blastmachine EBE 350 VH/ UNI	Control Voltage	Arch. nr.	PJ02.01745T1B	=	
Eng.	RJO			Draw. nr.	350-9110-VH/UNI	Pages	16
Print	14.08.2003					Page	9
Change	Date	Name	Status	As built			

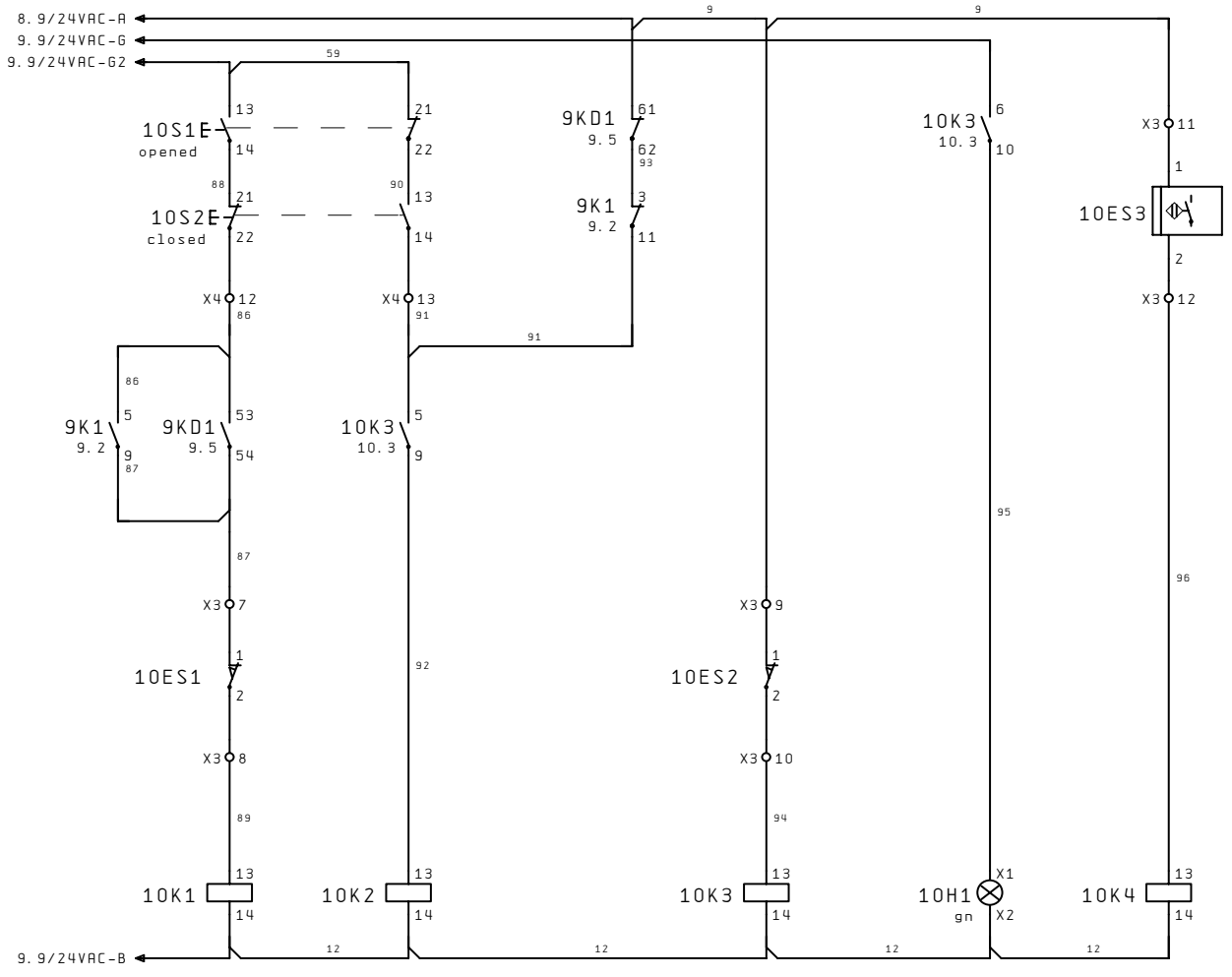

Shotvalve
opened

Shotvalve
closed

Proximity
switch

5 -> 9 7.1
6 -> 10 7.2
7 -> 11
8 -> 12

5 -> 9 7.2
6 -> 10 7.3
7 -> 11
8 -> 12

5 -> 9 10.2
6 -> 10 10.4
3 -> 11
4 -> 12

5 -> 9 9.3
6 -> 10
7 -> 11
8 -> 12

				Start	18.07.2002	USF BLASTRAC / EBE Blastmaschine EBE 350 VH/ UNI		Control Voltage		Arch. nr.	PJ02.01745T1B		=	
				Eng.	RJO					Draw. nr.	350-9110-VH/UNI		Pages	16
				Print	14.08.2003							Page	10	
Change	Date	Name	Status	As built										

X1

Internal connection	501:1	501:3	501:5	⊕
Bridges				
Terminal	L1	L2	L3	PE

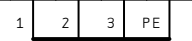

W5W1 4x

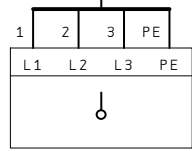

5W1

Supply 400V 50Hz.

Start	18.07.2002	USF BLASTRAC / EBE Blastmachine EBE 350 VH/ UNI		Terminal strip X1	Arch. nr.	PJ02.01745T1B	=	
Eng.	HLU				Draw. nr.	350-9110-VH/UNI	Pages	16
Print	14.08.2003				UNI	Page	11	
Change	Date	Name	Status	As built				

X2

Internal connection	9KM1: 2	9KM1: 4	9KM1: 6	⊕	9KM2: 2	9KM2: 4	9KM2: 6	9KD1: 2	9KD1: 4	9KD1: 6	⊕	9KM3: 2	9KM3: 4	9KM3: 6	⊕
Bridges															
Terminal	1	2	3	⊕	4	5	6	7	8	9	⊕	10	11	12	⊕

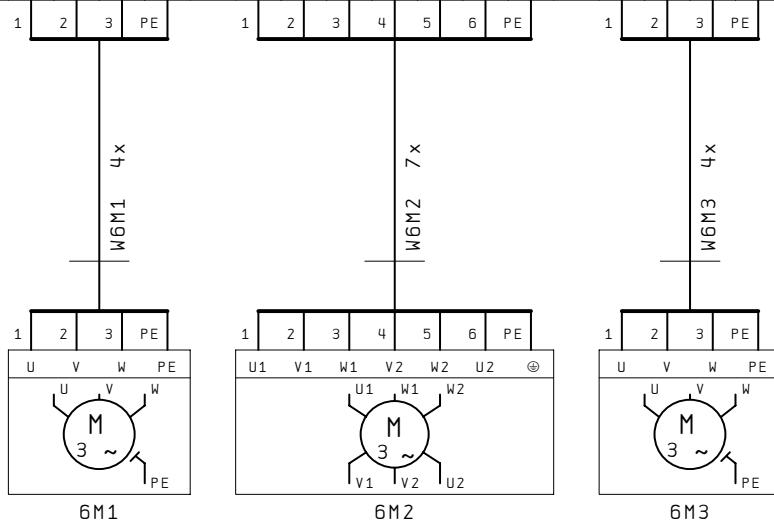

Elevator motor

Blast motor

Traverse motor

Start	18.07.2002	USF BLASTRAC / EBE Blastmachine EBE 350 VH/ UNI	Terminal strip X2	Arch. nr.	PJ02.01745T1B	=	
Eng.	HLU			Draw. nr.	350-9110-VH/UNI	Pages	16
Print	14.08.2003						
Change	Date	Name	Status	As built			



X3

Internal connection	7F1: 10K1:10		X4:7		601:13		9K01:54 10K1:13		9K01:61 X3:11 10K3:13		X3:9 10K4:13	
Bridges				●-----●								
Terminal	1	2	3	4	5	6	7	8	9	10	11	12

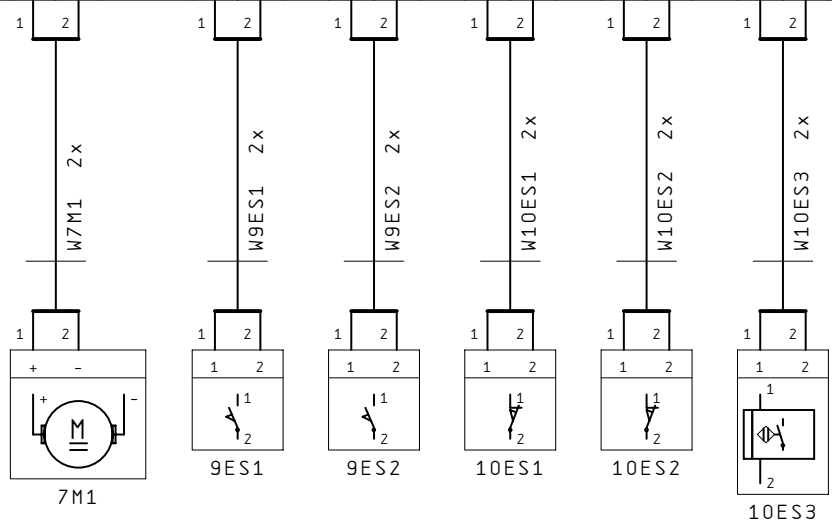

Shotvalve actuator

Limit switch

Limit switch

Limit switch

Limit switch

Proximity switch

Start	18.07.2002	USF BLASTRAC / EBE Blastmachine EBE 350 VH/ UNI		Terminal strip X3	Arch. nr.	PJ02.01745T1B	=	
Eng.	HLU				Draw. nr.	350-9110-VH/UNI	Pages	16
Print	14.08.2003				Page	13		
Change	Date				Name	Status	As built	

X4

Internal connection	8K1: B1	8K1: S21	8S2: 21	8S2: 11		9H1: X1 9KM1: 13	9KM1: 14		X3: 3		9KS1: 53		9KS1: 13		9KM4: 22	9KM3: 22		9K01: 53	10K3: 5		7U1: 13	7U1: 14	7U1: 11	7U1: 9	
Bridges																									
Terminal	1	3	4	5		5	6		7		8		9		10	11		12	13		14	15	16	17	

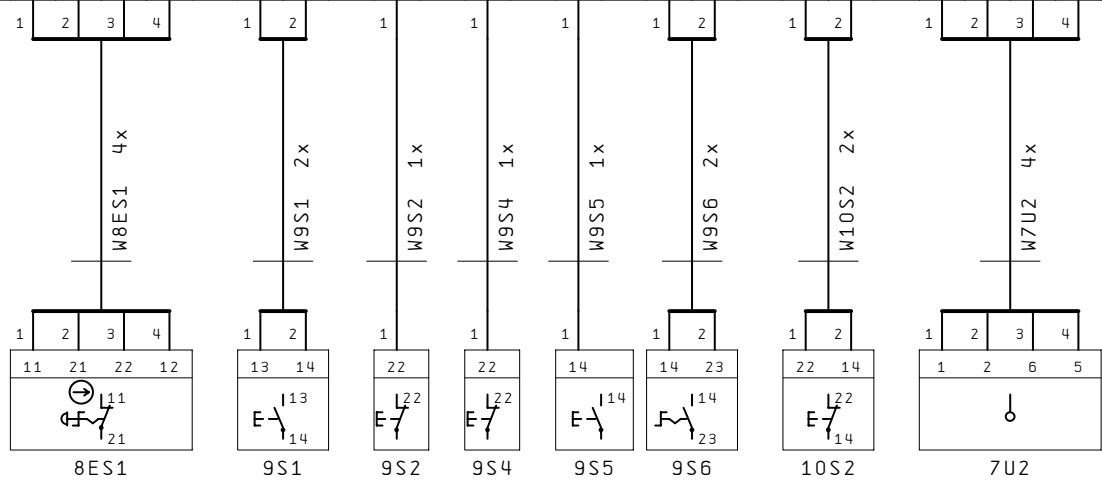

Emergency stop

24VAC-6

Start elevator motor

Stop elevator motor

Stop blast motor

Start blast motor

Traverse motor left

Traverse motor right

Shotvalve opened

Shotvalve closed

Digitale stroom uittezing

Materiaallijst

Onderdeel code	Pagina / pad	Artikelnummer	Typenummer	Omschrijving	Functie	Fabrikant	Aantal
5F1	5.2	16.01.0337	C60N 2P C4A	4A 2P UL/CSA		Merlin Gerin	1
5F2	5.3	11.07.0004	VUSI 4-10M	10mm2 grijs voor 5x20mm		Sprecher & Schuh	1
5F2	5.3	11.08.0014	VASI 4-10	voor VUSI 4-10		Sprecher & Schuh	1
5F2	5.3	16.02.0028	ZEK. GLAS TRAAG	glas 5x20mm slow 4A		Littelfuse	1
5F3	5.3	11.07.0004	VUSI 4-10M	10mm2 grijs voor 5x20mm		Sprecher & Schuh	1
5F3	5.3	11.08.0014	VASI 4-10	voor VUSI 4-10		Sprecher & Schuh	1
5F3	5.3	16.02.0028	ZEK. GLAS TRAAG	glas 5x20mm slow 4A		Littelfuse	1
5Q1	5.0	08.05.0020	V3	3-polig 63A		Telemecanique	1
5Q1	5.0	08.21.0003	VZ18	300..320mm voor V3..V6		Telemecanique	1
5Q1	5.0	08.13.0082	KAF-2PZ	zwart vergrendelbaar voor V3..V4		Telemecanique	1
5T1	5.2	VOLGT 1					1
5U1	5.4	21.06.0016	F40C25A	Brugcel 40V-25A, 28,5x28,5x22mm		Onbekend	1
5U2	5.5		F40C25A	Brugcel 40V-25A, 28,5x28,5x22mm		Onbekend	1
6Q1	6.1	01.01.0243	GV2-ME07	1,6..2,5A		Telemecanique	1
6Q1	6.1	01.08.0039	GV2-RE11	1m/1v voor GV2-M frontmontage		Telemecanique	1
6Q2	6.3	01.01.0250	GV2-ME22	20,0..25,0A		Telemecanique	1
6Q2	6.3	01.08.0039	GV2-RE11	1m/1v voor GV2-M frontmontage		Telemecanique	1
6Q3	6.7	01.01.0243	GV2-ME07	1,6..2,5A		Telemecanique	1
6Q3	6.7	01.08.0039	GV2-RE11	1m/1v voor GV2-M frontmontage		Telemecanique	1
7F1	7.1	11.07.0004	VUSI 4-10M	10mm2 grijs voor 5x20mm		Sprecher & Schuh	1
7F1	7.1	11.08.0014	VASI 4-10	voor VUSI 4-10		Sprecher & Schuh	1
7U1	7.4	15.08.0033	MCR-S-10/50-UI-DCI-N	stroomomvormer 0..55,0A > 4-20mA		Phoenix Contact B.V.	1
7U2	7.5	15.02.0049	MCR-SL-D-U/I	digitale uittezing, 5-digits		Phoenix Contact B.V.	1
8ES1	8.4	08.15.0053	ZB4-BS54	rood 40mm		Telemecanique	1
8ES1	8.4	08.15.0041	ZBY-9330	contrastschild geel rond 60mm + Emerg. Stop		Telemecanique	1
8ES1	8.4	08.12.0083	ZB4-BZ104	2v met koppelstuk		Telemecanique	1
8K1	8.2	03.13.0006	XPS-AS5140	24Vac/dc		Telemecanique	1
8K2	8.6	03.03.0020	55.34.8.024.0040	4w 5A spoel 24Vac		Finder	1
8K2	8.6	03.01.0037	94.04	14 pins t.b.v. relais 55.32/34		Finder	1
8S2	8.4	08.15.0053	ZB4-BS54	rood 40mm		Telemecanique	1
8S2	8.4	08.15.0041	ZBY-9330	contrastschild geel rond 60mm + Emerg. Stop		Telemecanique	1
8S2	8.4	08.12.0083	ZB4-BZ104	2v met koppelstuk		Telemecanique	1
9H1	9.0	08.04.0049	ZB5-RVB1	incl. protected LED, wit 24Vac/dc		Telemecanique	1
9H1	9.0	08.03.0086	ZB5-AV013	wit, t.b.v. intergral LED		Telemecanique	1
9H2	9.4	08.04.0050	ZB5-RVB3	incl. protected LED, groen 24Vac/dc		Telemecanique	1
9H2	9.4	08.03.0087	ZB5-AV033	groen, t.b.v. intergral LED		Telemecanique	1
9K1	9.2	03.03.0020	55.34.8.024.0040	4w 5A spoel 24Vac		Finder	1
9K1	9.2	03.01.0037	94.04	14 pins t.b.v. relais 55.32/34		Finder	1
9KD1	9.5	02.01.0408	LC1-D18-B7	3-pol. 7,5kW 400Vac hulp: 1m/1v spoel 24V 50/		Telemecanique	1
9KD1	9.5	02.02.0118	LAD-N11	1m/1v voor LC1-D09..LC1-D38		Telemecanique	1
9KM1	9.1	02.01.0404	LC1-D09-B7	3-pol. 4,0kW 400Vac hulp: 1m/1v spoel 24V 50/		Telemecanique	1
9KM1	9.1	02.02.0118	LAD-N11	1m/1v voor LC1-D09..LC1-D38		Telemecanique	1
9KM2	9.4	02.01.0408	LC1-D18-B7	3-pol. 7,5kW 400Vac hulp: 1m/1v spoel 24V 50/		Telemecanique	1
9KM2	9.4	02.04.0032	LAD-T2	pneumatisch 0,1..30 sec inschakel vertraagd		Telemecanique	1
9KM3	9.8	02.01.0404	LC1-D09-B7	3-pol. 4,0kW 400Vac hulp: 1m/1v spoel 24V 50/		Telemecanique	1
9KM3	9.8	02.12.0010	LAD-9R1V	en elektrisch voor LC1-D09/D38		Telemecanique	1
9KM4	9.8	02.01.0404	LC1-D09-B7	3-pol. 4,0kW 400Vac hulp: 1m/1v spoel 24V 50/		Telemecanique	1
9KS1	9.6	02.01.0404	LC1-D09-B7	3-pol. 4,0kW 400Vac hulp: 1m/1v spoel 24V 50/		Telemecanique	1
9KS1	9.6	02.02.0118	LAD-N11	1m/1v voor LC1-D09..LC1-D38		Telemecanique	1
9P1	9.6	15.02.0024	XB5-DSB	Urenteller 12/24V ac/dc 22mm.		Telemecanique	1

Start	18.07.2002	USF BLASTRAC / EBE Blastmachine EBE 350 VH/ UNI		Materiaallijst	Arch. nr.	PJ02.01745T1B	=	
Eng.	RJD				Draw. nr.	350-9110-VH/UNI	Pages	Page
Print	14.08.2003							
Change	Date	Name	Status	As built				

Materiaallijst

Onderdeel code	Pagina / pad	Artikelnummer	Typenummer	Omschrijving	Functie	Fabrikant	Aantal
9S1	9.1	08.01.0091	ZB5-AA0	zonder drukplaat		Telemecanique	1
9S1	9.1	08.12.0049	ZB5-AZ101	1m met koppelstuk		Telemecanique	1
9S2	9.1	08.01.0091	ZB5-AA0	zonder drukplaat		Telemecanique	1
9S2	9.1	08.12.0049	ZB5-AZ101	1m met koppelstuk		Telemecanique	1
9S3	9.2	08.13.0106	ZB5-AD2	zwart 2-standen		Telemecanique	1
9S3	9.2	08.12.0051	ZB5-AZ103	2m met koppelstuk		Telemecanique	1
9S4	9.4	08.01.0091	ZB5-AA0	zonder drukplaat		Telemecanique	1
9S4	9.4	08.12.0049	ZB5-AZ101	1m met koppelstuk		Telemecanique	1
9S5	9.4	08.01.0091	ZB5-AA0	zonder drukplaat		Telemecanique	1
9S5	9.4	08.12.0049	ZB5-AZ101	1m met koppelstuk		Telemecanique	1
9S6	9.8	08.30.0001	XD2-PA22	zwenkschakelaar 2 richtingen		Telemecanique	1
9S6	9.8	08.12.0051	ZB5-AZ103	2m met koppelstuk		Telemecanique	1
10H1	10.4	08.04.0050	ZB5-RVB3	incl. protected LED, groen 24Vac/dc		Telemecanique	1
10H1	10.4	08.03.0087	ZB5-AV033	groen, t.b.v. intergral LED		Telemecanique	1
10K1	10.1	03.03.0020	55.34.8.024.0040	4w 5A spoel 24Vac		Finder	1
10K1	10.1	03.01.0037	94.04	14 pins t.b.v. relais 55.32/34		Finder	1
10K2	10.2	03.03.0020	55.34.8.024.0040	4w 5A spoel 24Vac		Finder	1
10K2	10.2	03.01.0037	94.04	14 pins t.b.v. relais 55.32/34		Finder	1
10K3	10.3	03.03.0020	55.34.8.024.0040	4w 5A spoel 24Vac		Finder	1
10K3	10.3	03.01.0037	94.04	14 pins t.b.v. relais 55.32/34		Finder	1
10K4	10.5	03.03.0020	55.34.8.024.0040	4w 5A spoel 24Vac		Finder	1
10K4	10.5	03.01.0037	94.04	14 pins t.b.v. relais 55.32/34		Finder	1
10S1	10.1	08.01.0091	ZB5-AA0	zonder drukplaat		Telemecanique	1
10S1	10.1	08.12.0053	ZB5-AZ105	1m/1v met koppelstuk		Telemecanique	1
10S2	10.1	08.01.0091	ZB5-AA0	zonder drukplaat		Telemecanique	1
10S2	10.1	08.12.0053	ZB5-AZ105	1m/1v met koppelstuk		Telemecanique	1

Contents Chapter 9

9.1 Fault diagnosis - blast machine

9.2 Fault diagnosis - electrical system

Fault diagnosis

9.1 Fault diagnosis - blast machine



Prior to any repair works on the machine or its drives the machine must be secured against unintentional switching-on. Put the machine to its Safety off position.

Fault	Possible cause	Remedy
Excessive vibration	Blast wheel is worn irregularly. Imbalance due to worn or broken wheel blades.	Replace the worn blast wheel parts and remove all broken parts from the machine.
Unusual noise	Too little play or poor alignment of the rotating parts.	Check alignment of the rotating parts (blast wheel and control cage).
	Loose and incorrect set screws.	Check whether all screws and parts are fixed tightly.
	Squeaking wheels.	Replace the wheels.
Reduced or no blasting performance	Seizing motor.	Replace the motor.
	Inadequate abrasive supply to the blast wheel.	Clean wire mesh, top up abrasive if necessary.
	Contaminated abrasive.	Abrasive is heavily contaminated, check the ventilation system.
	Feeding of abrasive shot valve and abrasive storage hopper.	Check and clean blocked shot valve housing.

Fault diagnosis

Fault	Possible cause	Remedy
Reduced or no blasting performance	Blast wheel or control cage.	Worn blast wheel or control cage, replace worn parts if necessary.
	Adjustment of the shot valve.	Check the adjustment of the valve.
	"Shocked blast wheel". At the start of the blast process too much abrasive at once hits the wheel.	Close the shot valve and stop the blast wheel motor. Start the blast process again and slowly open the valve.
	The travel speed is too high.	Reduce the travel speed.
Escaping abrasive	Poor sealing.	Check all seals and replace if necessary.
Abrasive loss on the surface or escaping abrasive at the blast head	Poor abrasive quality.	Contact ISPC Blastrac/EBE .
	Worn blast wheel parts.	Replace worn blast wheel parts.
Contaminated abrasive	The filter unit is not generating enough suction power so that dust remains in the abrasive.	Check the filter unit (cartridges and seals).

Fault diagnosis

Fault	Possible cause	Remedy
Excessive wear in blast housing and recovery duct	Wrong abrasive. Incorrect setting of the control cage	Contact ISPC Blastrac/EBE . The thrown abrasive blasts the housing and not the surface to be blasted. Adjust the blast pattern.

9.2 Fault diagnosis - electrical system



Prior to any repair works on the machine or its drives the machine must be secured against unintentional switching-on. Put the machine to its Safety off position.

Fault	Possible cause	Remedy
Control system does not switch on	Motor protection switch has triggered.	Check and switch on again. Check the mains power supply.

Fault diagnosis

Fault	Possible cause	Remedy
Control system switches off during operation	Connection cable is defective.	Replace the cable.
	Cables connecting the units (travel motor, etc.) are defective.	Replace the cable.
	Motor protection switch have triggered.	Have the fault checked by an electrician.
	Main switch of the filter unit switches off due to overload.	Switch the main switch "ON" - with fault, have the unit checked by an electrician.
Machine does not travel	Fuse defective or short circuit in the travel motor lead or tachometer lead, motor defective.	Have the unit checked by an electrician.
	Control unit defective.	Replace the control unit.
	Drive wheel joystick defective.	Replace the joystick.

Note: If the motor protection switch of the blast wheel motor has been triggered by overload, it can be switched on again after a short cooling down period.

Contents Chapter 10

10.1 Spare parts

Spare parts

10.1 Spare parts

Blast housing and seals

Item	Part no.	Description	Qty.
1	350-1073-V	Innerseal top	1
2	350-1510-VH	Innerseal strap top	1
3	350-1077-V	Innerseal left/right	2
4	350-1079-VH	Innerseal strap left/right	2
5	350-1511-VH	Innerseal strap bottom	1
6	350-1074-V	Innerseal bottom	1
7	350-1082-VH	Mouth seal plate	1
8	350-1080-V	Mouth seal	1
9	350-9006-VH	Blast housing cabinet	1
10	350-1505-VH	Inner mouth strap	1
11	350-1115	Top liner cover	1
12	350-1068-VH	Grit funnel	1

Spare parts

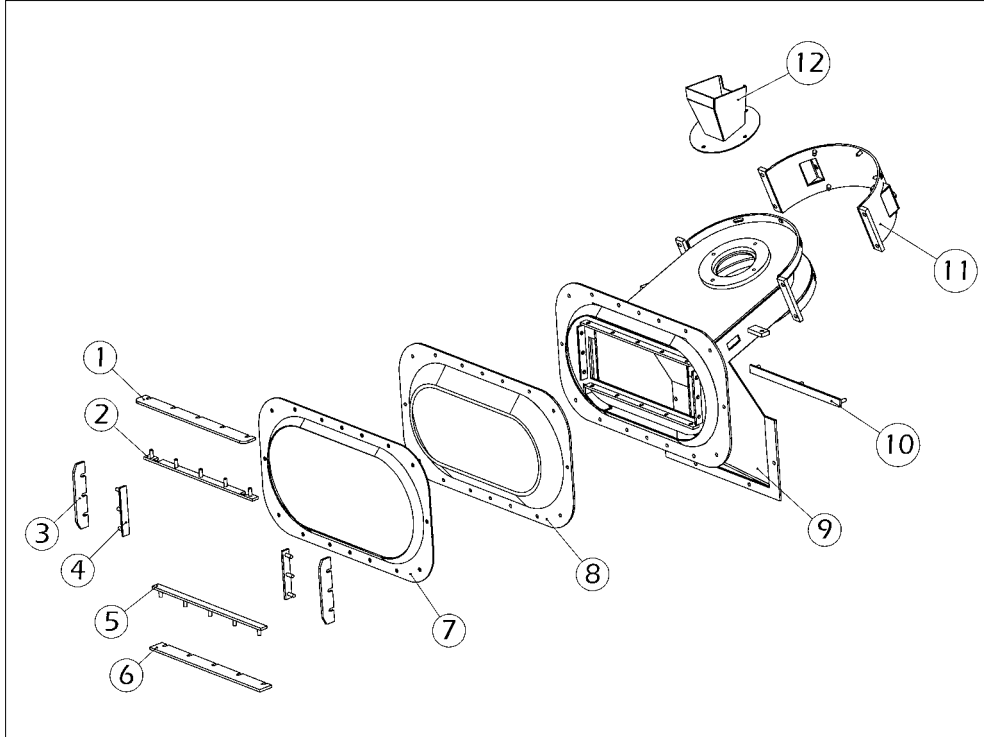

Fig. 10.1

Spare parts

Blast wheel parts and liners

Item	Part no.	Description	Qty.
1	350-1245-SEV	Impeller bolt	1
2	350-9041	Cage clamp	-
3	350-1010	Control cage	1
4	350-1015	Impeller	1
5	350-1005	Blades (set of 6)	1
6	350-1025	Blastwheel	1
7	222-2265	Taperlock adapter blastwheel	1
8	222-2290	Blastwheel shaft taperlock bush	1
9	350-1030-VH	Liner LH	1
10	350-1035-VH	Liner RH	1
11	350-1040	Top liner	1

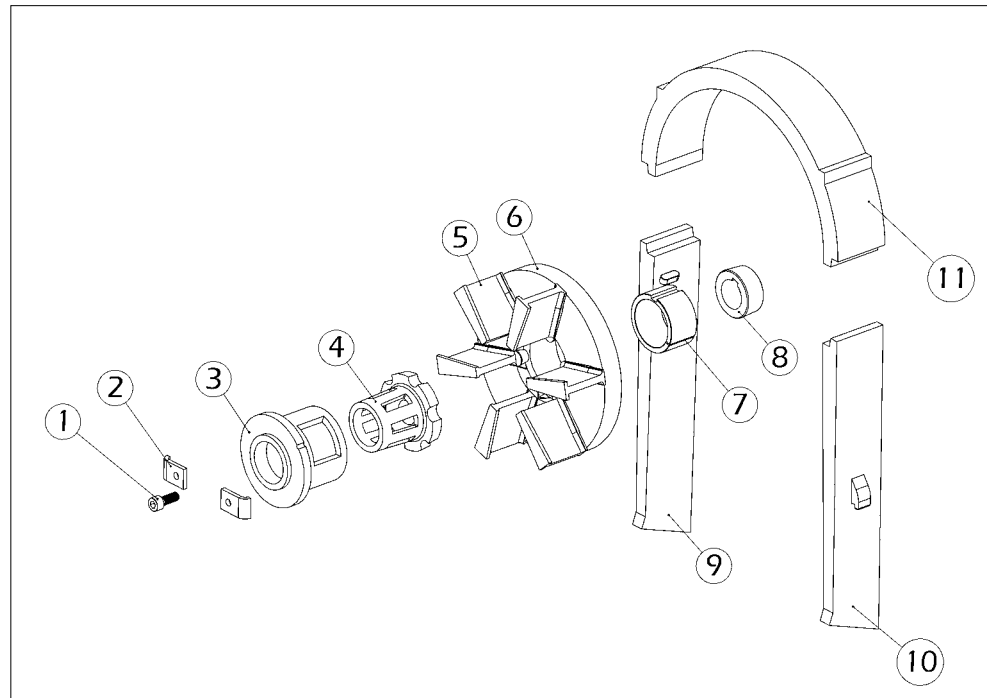

Fig. 10.2

Separator and hopper

Item	Part no.	Description	Qty.
1	-	Separator (part of elevator housing)	1
2	E00971	Baffle plate	1
3	350-1067-VH	Abrasive storage hopper	1
4	-	Door lock (part of hopper)	1
5	350-9240-VH	Shot valve axle housing	1
6	222-2080-V	Bearing seal	2
7	222-2250-V	Bearing	2
8	350-1071-SE	Shot valve insert steel	2
9	350-1070-SE	Shot valve insert rubber	1
10	350-2015-VH	Shot valve axle	1
11	350-2016-VH	Shot valve actuator mount	1

Spare parts

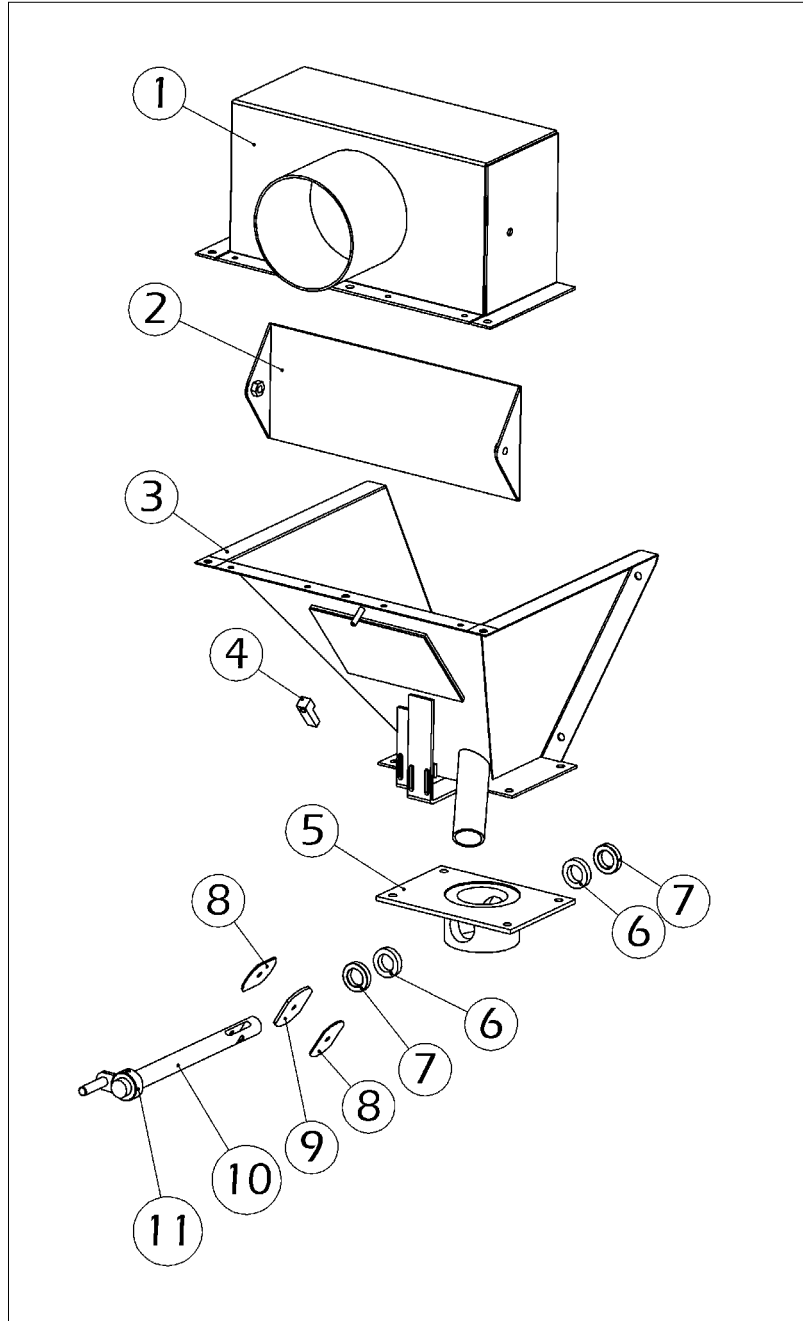

Fig. 10.3

Spare parts

Elevator

Item	Part no.	Description	Qty.
1	222-2243-V	Elevator tension bearing	2
2	350-9250-VH	Metal sealing for tension bearing	2
3	350-9056-VH	Elevator support roll	3
4	350-2248-VH	Support shaft bottom pulley	3
5	350-9055-VH	Elevator drive roll	1
6	222-2242-V	Bearing for elevator & bobbin	6
7	350-2247-VH	Drive shaft tension pulley	1
8	350-2505-VH	Elevator bucket	30
9	350-2500-VH	Elevator belt complete	1
10	E00979	Grit support plate	1
11	E00980	Elevator bottom cover	1
12	-	Elevator housing (part of machine)	1
13	350-3065-VH	Elevator motor 0,75 kW	1
14	222-2535-VH	Elevator motor sprocket	1
15	222-2285-V	Taperlock bush	2
16	350-2214-VH	Elevator drive chain	1
17	222-2018-VH	Sprocket (50Hz)	1
	222-2020-EV	Sprocket (60Hz)	1
18	E00981	Elevator top cover	1
19	E00982	Top cover air plate	1
20	E00972	Elevator motor chain guard	1

Spare parts

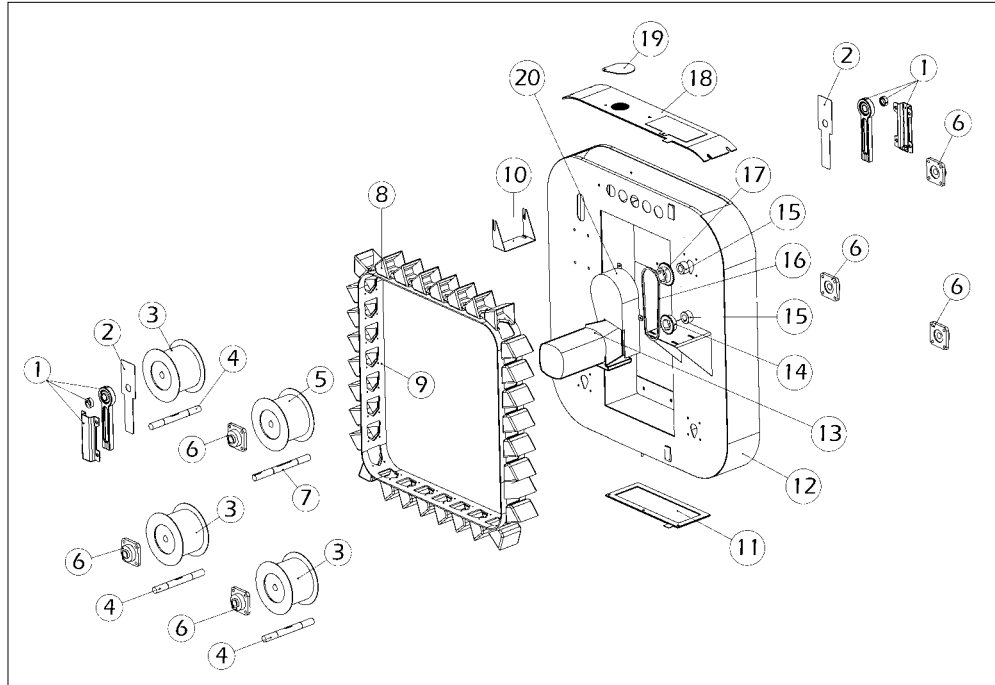

Fig. 10.4

Blast wheel drive

Item	Part no.	Description	Qty.
1	350-3020-VH	Blastmotor 11kW	1
2	350-2170-VH	Belt pulley (50Hz)	1
	350-2182-V	Belt pulley (60Hz)	1
3	222-2290	Blastwheel shaft taperlock bush	1
4	350-2431-V	Blastmotor belt (set of 3)	1
5	350-9255-VH	Blastwheel belt guard	1
6	350-9007-SEVU	Mounting plate	1
7	350-2451-SEV	Blastwheel bearing house complete	1
8	350-2464-V	Blastwheel pulley spacer (50Hz)	1
	350-2463-SEVU	Blastwheel pulley spacer (60Hz)	1
9	350-2346-VH	Belt pulley (50Hz)	1
	350-2346-V	Belt pulley (60Hz)	1

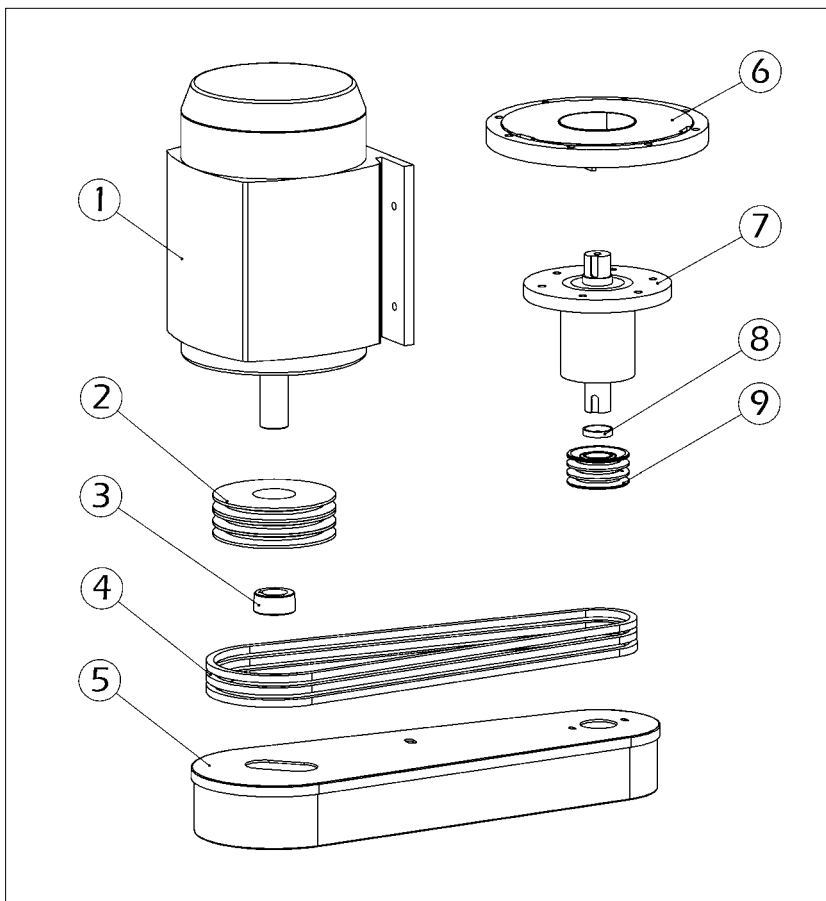

Fig. 10.5

Spare parts
Drive system

Item	Part no.	Description	Qty.
1	350-2010-SEV	Front wheel castor complete	2
2	350-2012-V	Front wheel spacer block	2
3	350-2014-V	Front wheel spacer 5mm	2
4	E00938	Magnet front cover	2
5	350-2515-VH	Magnet	2
6	E00937	Magnet rear cover	2
7	350-1116-VH	Magnet plate	2
8	E00945	Bobbin frame	1
9	350-1108-VH	Drive motor protector	1
10	222-2811-VH	Sprocket	2
11	350-2510-VH	Bobbin soft (compl. with shaft)	2
12	350-2213-VH	Drive motor chain (short)	1
13	350-3345-VH	Bobbin drive motor	1
14	222-2810-VH	Sprocket	2
15	350-2213-V	Drive motor chain (long)	1
16	222-2242-V	Bearing for elevator & bobbin	4
17	350-2813-VH	Bobbin drive shaft	2
18	350-2816-VH	Bobbin spacer 33 mm	2
19	350-2815-VH	Bobbin spacer 60 mm	2
20	350-2814-VH	Bobbin spacer 75 mm	2
21	500-9060-VH	Bobbin drive disk & 8 brackets	2
22	222-2230-V	Bearing	32
23	999-1220-V	Bobbin shaft	16
24	350-2507-VH	Bobbin soft	16

Spare parts

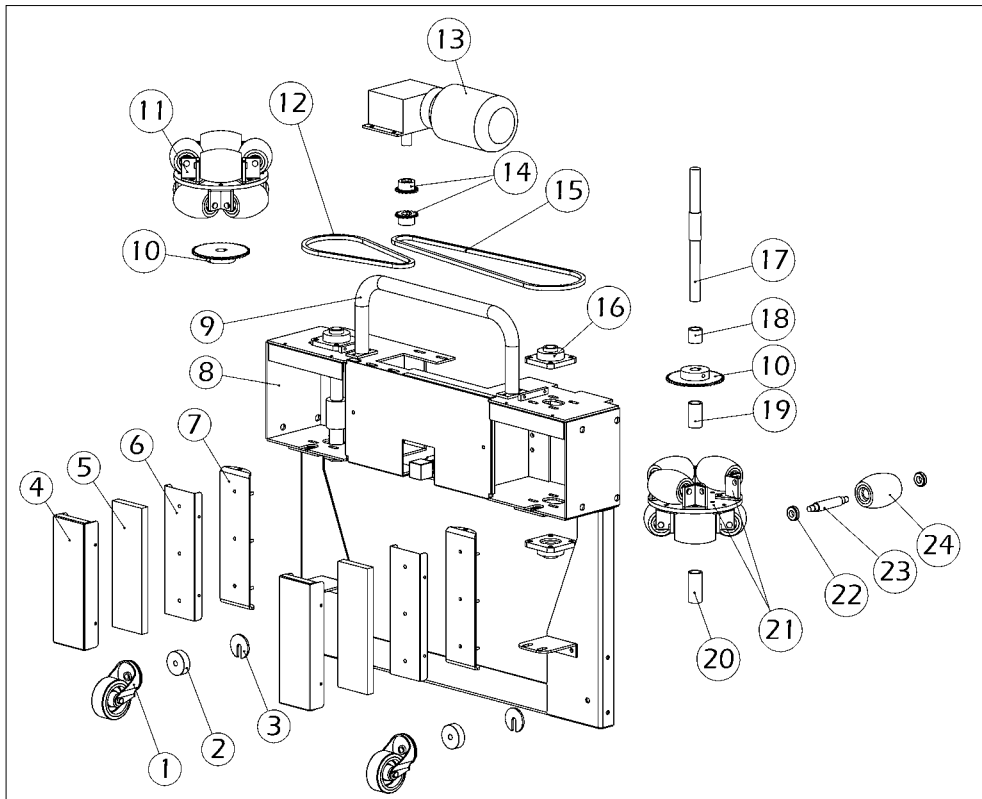

Fig. 10.6

Spare parts

Protection frame, Hoist arm & Electrical components

Item	Part no.	Description	Qty.
1	350-9505-VH	Hoist beam complete	1
2	-	Protection frame (part of machine)	1
3	035-3191-VH	Abrasive valve actuator	1
4	035-3192	Actuator motor	1
5	035-3193-VH	Actuator motor cover (set of 2)	1
6	333-3440	Reed contactor limit switch	2
7	500-9070-VH	Cable support	1
8	350-9110-VH	Electrobox complete	1
9	333-3498	Limit switch	2
10	333-3507	Roll lever for limit switch	2
11	350-3345-VH	Bobbin drive motor	1
12	035-3365-VH	Proximity switch	1
13	023-2071	Plug 32A - 4p - 380V	1

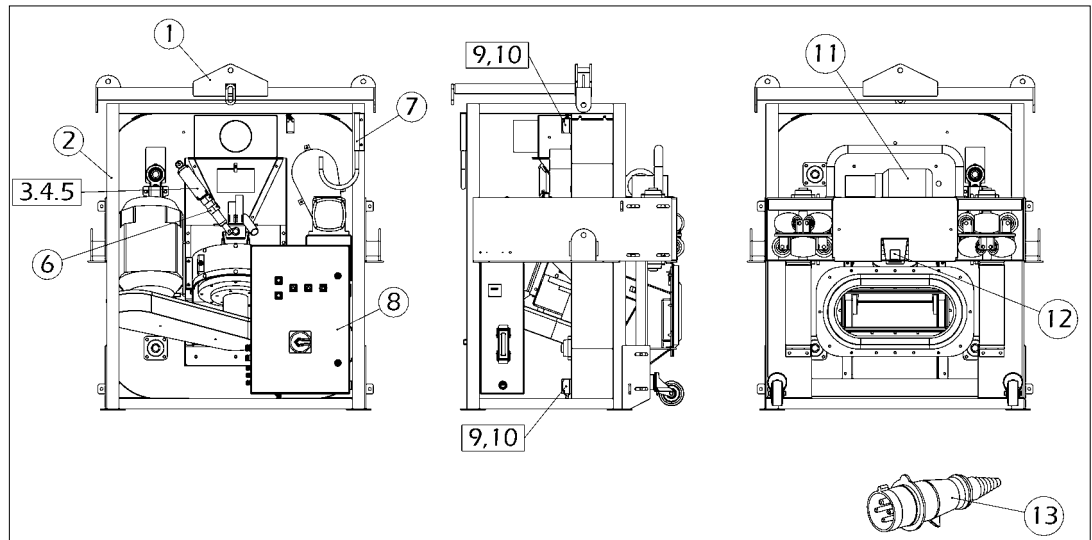

Fig. 10.7